

# Product Catalogue

 car  Aviation  Ships  Mechanical  electronic



# 2025

Live Tools for CNC Lathes/  
Tools for CNC Lathes

# CONTENTS



**STAR**  
*P1-P17*



**TSUGAMI**  
*P18-P25*



**HANWHA**  
*P51-P55*



**CINCOM**  
*P26-P38*



**JINFA**  
*P56*



**MIYANO**  
*P39-P43*



**DOOSAN**  
*P57-P58*



**CHIAH CHYUN**  
*P44-P46*



**NAKAMURA**  
*P59-P60*



**NOMURA**  
*P47-P50*



**GOODWAY**  
*P61*

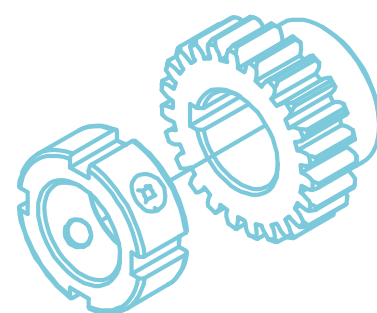

## ECAS, SB, SR, SW

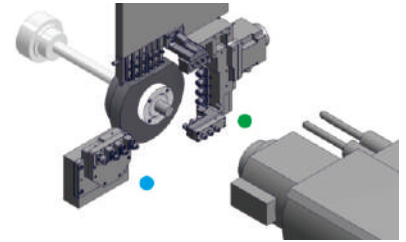

**Drilling/milling unit**

Product No.	<b>STRA2A1203</b>
Ref. No.	57151
Speed ratio	1:1
RPM Max.	6000
Tool clamping	ER16M

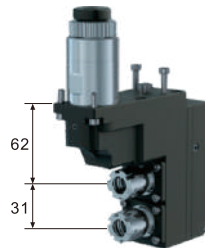

**2-spindle drilling/milling unit**

Product No.	<b>STRA2A2204</b>
Ref. No.	54151
Speed ratio	1:1
RPM Max.	6000
Tool clamping	ER16M

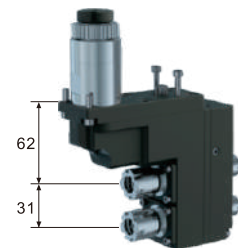

**2-spindle double drilling/milling unit**

Product No.	<b>STRA2B2202</b>
Ref. No.	66159
Speed ratio	1:1
RPM Max.	6000
Tool clamping	ER16M/ER11M



**2-spindle double drilling/milling unit**

Product No.	<b>STWA2B2101</b>
Ref. No.	10156
Speed ratio	1:1
RPM Max.	12000
Tool clamping	ER11M/ER8M

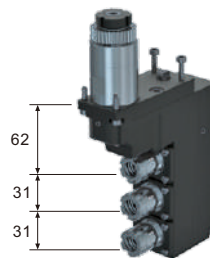

**3-spindle drilling/milling unit**

Product No.	<b>STRA2A3204</b>
Ref. No.	—
Speed ratio	1:1
RPM Max.	6000
Tool clamping	ER16M

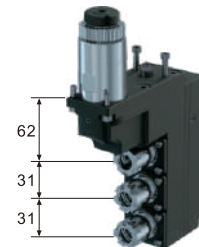

**3-spindle drilling/milling unit**

Product No.	<b>STRA2A3201</b>
Ref. No.	66151
Speed ratio	1:1
RPM Max.	6000
Tool clamping	ER16M

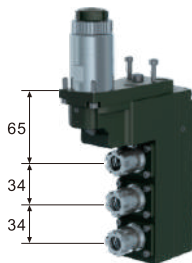

**3-spindle drilling/milling unit**

Product No.	<b>STRA2A3301</b>
Ref. No.	67151
Speed ratio	1:1
RPM Max.	6000
Tool clamping	ER16M

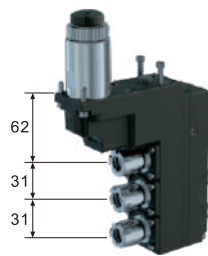

**3-spindle double drilling/milling unit**

Product No.	<b>STRA2B3201</b>
Ref. No.	67161
Speed ratio	1:1
RPM Max.	6000
Tool clamping	ER16M/ER11M

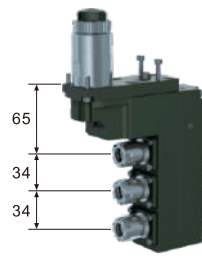

**3-spindle double drilling/milling unit**

Product No.	<b>STRA2B3301</b>
Ref. No.	67159
Speed ratio	1:1
RPM Max.	6000
Tool clamping	ER16M/ER11M



**3-spindle double drilling/milling unit**

Product No.	<b>STRA2B3203</b>
Ref. No.	—
Speed ratio	1:1
RPM Max.	6000
Tool clamping	ER16M/ER11M

# ECAS, SB, SR, SW

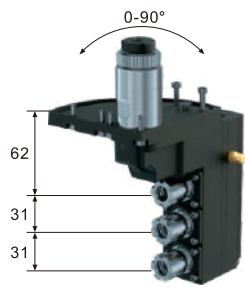
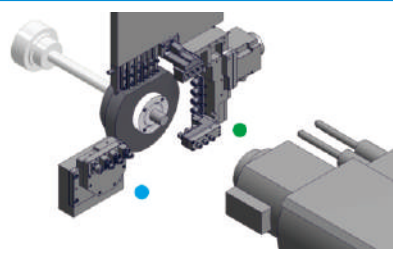

**3-spindle drilling/milling unit** ↕

Product No.	<b>STRA2A3202</b>
Ref. No.	—
Speed ratio	1:1
RPM Max.	6000
Tool clamping	ER16M

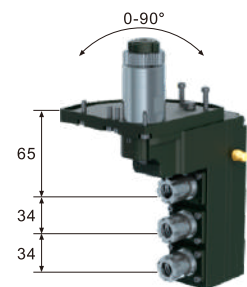

**3-spindle drilling/milling unit** ↕

Product No.	<b>STRA2A3302</b>
Ref. No.	—
Speed ratio	1:1
RPM Max.	6000
Tool clamping	ER16M

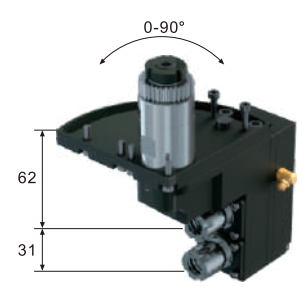

**2-spindle drilling/milling unit** ↕

Product No.	<b>STRA2A2202</b>
Ref. No.	—
Speed ratio	1:1
RPM Max.	6000
Tool clamping	ER16M

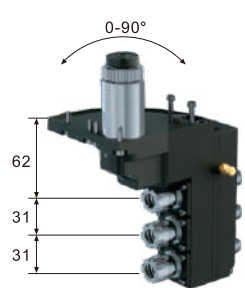

**3-spindle double drilling/milling unit** ↕

Product No.	<b>STRA2B3202</b>
Ref. No.	—
Speed ratio	1:1
RPM Max.	6000
Tool clamping	ER16M/ER11M

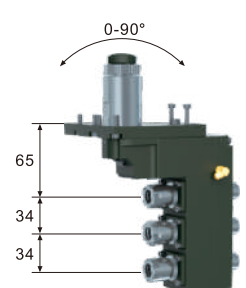

**3-spindle double drilling/milling unit** ↕

Product No.	<b>STRA2B3302</b>
Ref. No.	—
Speed ratio	1:1
RPM Max.	6000
Tool clamping	ER16M/ER11M

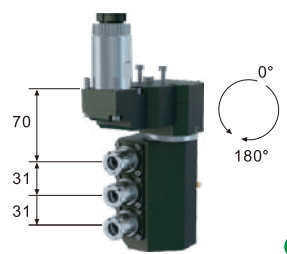

**3-spindle drilling/milling unit** ↕

Product No.	<b>STRA2A3207</b>
Ref. No.	—
Speed ratio	1:1
RPM Max.	6000
Tool clamping	ER16M

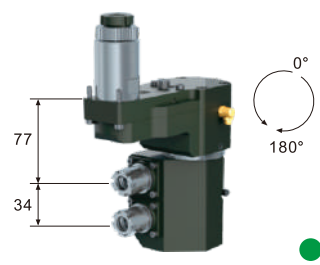

**2-spindle drilling/milling unit** ↕

Product No.	<b>STRA2A2303</b>
Ref. No.	—
Speed ratio	1:1
RPM Max.	6000
Tool clamping	ER16M

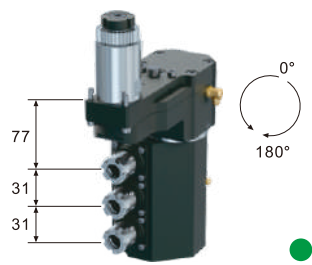

**3-spindle drilling/milling unit** ↕

Product No.	<b>STRA2A3203</b>
Ref. No.	—
Speed ratio	1:1
RPM Max.	6000
Tool clamping	ER16M

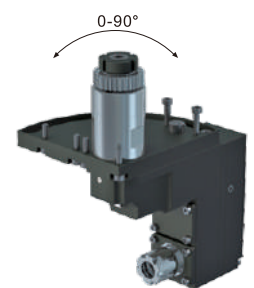

**Drilling/milling unit, Angle adj. 0-90°** ↕

Product No.	<b>STRA2A1205</b>
Ref. No.	—
Speed ratio	1:1
RPM Max.	6000
Tool clamping	ER16M

## ECAS, SB, SR, SW

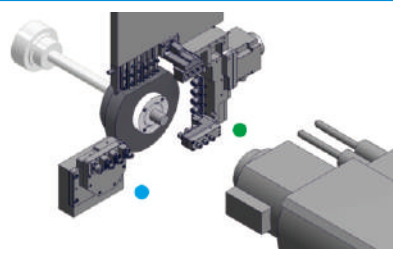

**Axial drilling/milling unit**

Product No.	<b>STRA116204</b>
Ref. No.	—
Speed ratio	1:1
RPM Max.	6000
Tool clamping	Ø 10.5/M10x1.5



**Cross drilling/milling unit**

Product No.	<b>STRA116201</b>
Ref. No.	57155
Speed ratio	1:1
RPM Max.	8000
Tool clamping	ER16M



**Cross drilling/milling unit**

Product No.	<b>STRA116202/STRA120201</b>
Ref. No.	33150
Speed ratio	1:1
RPM Max.	8000
Tool clamping	ER16M / ER20M

**high speed**



**Cross drilling/milling unit**

Product No.	<b>STRA111202</b>
Ref. No.	—
Speed ratio	1:3 
RPM Max.	18000
Tool clamping	ER11A

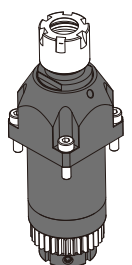

**Cross drilling/milling unit**

Product No.	<b>STRA116209</b>
Ref. No.	57155
Speed ratio	1:1
RPM Max.	8000
Tool clamping	ER16M



**Cross drilling/milling unit**

Product No.	<b>STRA116210</b>
Ref. No.	331-50-00
Speed ratio	1:1
RPM Max.	8000
Tool clamping	ER16M



**Cross drilling/milling unit, 3-spindle**

Product No.	<b>STRA111201</b>
Ref. No.	—
Speed ratio	1:1
RPM Max.	8000
Tool clamping	ER11M



**Slotting unit**

Product No.	<b>STRA706201/STRA712201/STRA713201</b>
Ref. No.	54153
Speed ratio	1:0.374 
RPM Max.	4000
Tool clamping	鋸片 Ø6/Ø12.7/Ø13xØ50

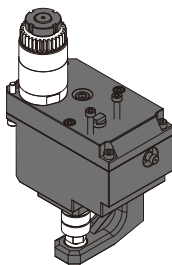

**Slotting unit**

Product No.	<b>STRA712204</b>
Ref. No.	—
Speed ratio	1:0.374 
RPM Max.	4000
Tool clamping	Ø50



**Slotting unit**

Product No.	<b>STRA713202</b>
Ref. No.	—
Speed ratio	1:0.375 
RPM Max.	4000
Tool clamping	鋸片 Ø13xØ50



**Thread whirling unit** 

Product No.	<b>STRA545203</b>
Ref. No.	68172
Speed ratio	1:1
RPM Max.	6000
Tool clamping	Utilis no.119287

# ECAS, SB, SR, SW

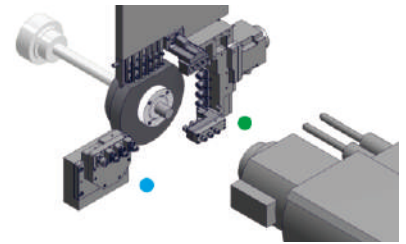

※Option: cutter

### Polygon unit

Product No.	<b>STRA400201</b>
Ref. No.	OT191
Speed ratio	1:1
RPM Max.	3000
Tool clamping	—

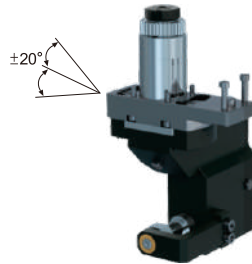

### Gear hobbing unit

Product No.	<b>STRA613201/STRA610201</b>
Ref. No.	—
Speed ratio	1:1
RPM Max.	6000
Tool clamping	滾齒刀 $\varnothing 13 \times \varnothing 30 \times 20 / \varnothing 10$



### Boring bar holder

Product No.	<b>STRA803309</b>
Ref. No.	—
Speed ratio	—
RPM Max.	—
Tool clamping	$\varnothing 22$



### Boring bar holder

Product No.	<b>STRA803307</b>
Ref. No.	—
Speed ratio	—
RPM Max.	—
Tool clamping	$\varnothing 22$



### Idler shaft

Product No.	<b>STRA100000</b>
Ref. No.	57189
Speed ratio	—
RPM Max.	—
Tool clamping	—

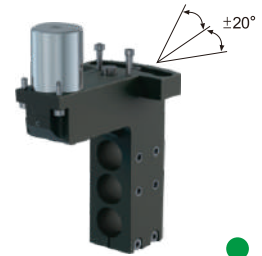

### Air tool holder

Product No.	<b>STRA0002</b>
Ref. No.	—
Speed ratio	—
RPM Max.	—
Tool clamping	$\varnothing 22$



### Air tool holder

Product No.	<b>STBA0004</b>
Ref. No.	—
Speed ratio	—
RPM Max.	—
Tool clamping	$\varnothing 22$



### Air tool holder

Product No.	<b>STRA0014</b>
Ref. No.	—
Speed ratio	—
RPM Max.	—
Tool clamping	$\varnothing 25$



### Air tool holder for sub spindle

Product No.	<b>STRB0003</b>
Ref. No.	—
Speed ratio	—
RPM Max.	—
Tool clamping	$\varnothing 20$

## ECAS, SB, SR, SW

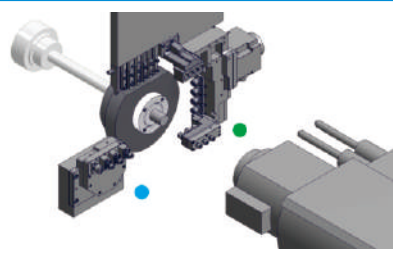

**Air tool holder for sub spindle**

Product No.	<b>STRB0001</b>
Ref. No.	—
Speed ratio	—
RPM Max.	—
Tool clamping	Ø22.8



**Slotting unit for sub spindle** ⚙️

Product No.	<b>STRB700201</b>
Ref. No.	69166/69165
Speed ratio	1:0.55 ⚙️
RPM Max.	4000
Tool clamping	Ø5/6/8/10/12.7/13xØ50



**Slotting unit for sub spindle** ⚙️

Product No.	<b>STRB700202</b>
Ref. No.	0R165
Speed ratio	1:0.55 ⚙️
RPM Max.	4000
Tool clamping	Ø5/6/8/10/12.7/13xØ50



**Drilling/milling unit for sub spindle**

Product No.	<b>STRB111210</b>
Ref. No.	54161
Speed ratio	1:4 ⚙️
RPM Max.	24000
Tool clamping	ER11A



**Drilling/milling unit for sub spindle**

Product No.	<b>STRB111213</b>
Ref. No.	0R161
Speed ratio	1:1 ⚙️
RPM Max.	6000
Tool clamping	ER11M



**Drilling/milling unit for sub spindle**

Product No.	<b>STRB116205</b>
Ref. No.	—
Speed ratio	1:1
RPM Max.	8000
Tool clamping	M6X1



**Drilling/milling unit for sub spindle**

Product No.	<b>STRB116206</b>
Ref. No.	10181
Speed ratio	1:1
RPM Max.	6000
Tool clamping	ER16M



**Drilling/milling unit for sub spindle**

Product No.	<b>STRB111208</b>
Ref. No.	54161
Speed ratio	1:1
RPM Max.	6000
Tool clamping	ER11M

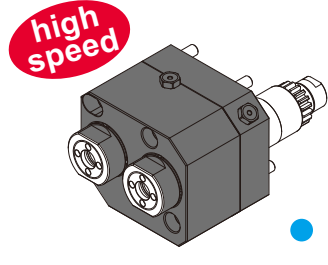

**Drilling/milling unit for sub spindle**

Product No.	<b>STRB111209</b>
Ref. No.	—
Speed ratio	1:3 ⚙️
RPM Max.	18000
Tool clamping	ER11

## ECAS, SB, SR, SW

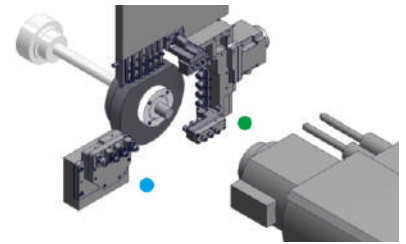

Drilling/milling unit for sub spindle

Product No.	<b>STRB116201</b>
Ref. No.	OR161
Speed ratio	1:1
RPM Max.	6000
Tool clamping	ER16M



Drilling/milling unit for sub spindle

Product No.	<b>STRB116202/STRB116203</b>
Ref. No.	57161
Speed ratio	1:1
RPM Max.	6000
Tool clamping	ER16M/ER16A

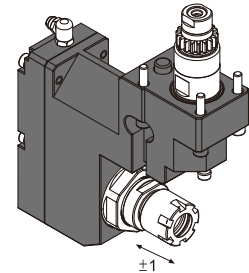

Cross drilling/milling unit for sub spindle

Product No.	<b>STRB316204</b>
Ref. No.	OR151
Speed ratio	1:1
RPM Max.	6000
Tool clamping	ER16M



Drilling/milling unit for sub spindle, 3-spindle

Product No.	<b>STRB108101</b>
Ref. No.	—
Speed ratio	1:1
RPM Max.	8000
Tool clamping	ER8M



Drilling/milling unit for sub spindle, 3-spindle

Product No.	<b>STRB111201</b>
Ref. No.	0E151
Speed ratio	1:1
RPM Max.	8000
Tool clamping	ER11M

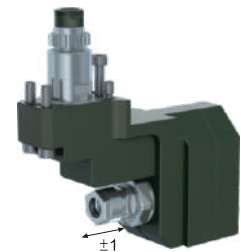

Cross drilling/milling unit for sub spindle

Product No.	<b>STRB311201</b>
Ref. No.	69166
Speed ratio	1:0.55
RPM Max.	4000
Tool clamping	ER11A

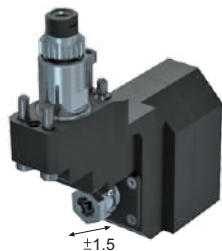

Cross drilling/milling unit for sub spindle

Product No.	<b>STRB311205</b>
Ref. No.	—
Speed ratio	1:0.55
RPM Max.	4000
Tool clamping	ER11A



Cross drilling/milling unit for sub spindle

Product No.	<b>STRB316201</b>
Ref. No.	OR151
Speed ratio	1:1
RPM Max.	6000
Tool clamping	ER16M



Cross drilling/milling unit for sub spindle

Product No.	<b>STRB316202</b>
Ref. No.	—
Speed ratio	1:0.77
RPM Max.	4000
Tool clamping	ER16A

## ECAS, SB, SR, SW

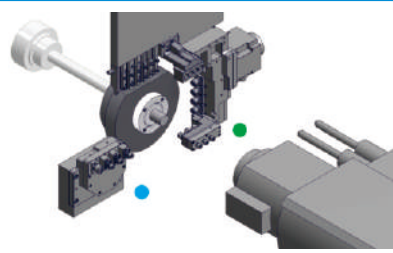

Cross drilling/milling unit for sub spindle

Product No.	<b>STRB311101</b>
Ref. No.	—
Speed ratio	1:1
RPM Max.	6000
Tool clamping	ER11

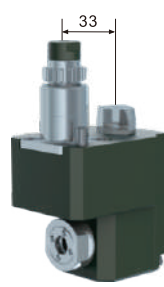

Cross drilling/milling unit for sub spindle

Product No.	<b>STRB311204</b>
Ref. No.	—
Speed ratio	1:1
RPM Max.	6000
Tool clamping	ER11

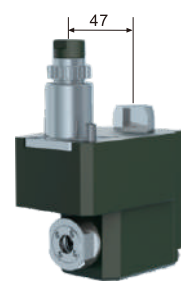

Cross drilling/milling unit for sub spindle

Product No.	<b>STRB311301</b>
Ref. No.	—
Speed ratio	1:1
RPM Max.	6000
Tool clamping	ER11



Cross drilling/milling unit for sub spindle

Product No.	<b>STRB311203</b>
Ref. No.	0E152
Speed ratio	1:1
RPM Max.	8000
Tool clamping	ER11M



Cross drilling/milling unit for sub spindle

Product No.	<b>STRB320301</b>
Ref. No.	—
Speed ratio	1:1
RPM Max.	6000
Tool clamping	ER-20M



Drilling/milling unit for sub spindle

Product No.	<b>STRB111101</b>
Ref. No.	—
Speed ratio	1:1
RPM Max.	8000
Tool clamping	ER11



Drilling/milling unit for sub spindle

Product No.	<b>STRB111203</b>
Ref. No.	—
Speed ratio	1:1
RPM Max.	8000
Tool clamping	ER11(内螺帽)



Drilling/milling unit for sub spindle

Product No.	<b>STRBB111201</b>
Ref. No.	—
Speed ratio	1:1
RPM Max.	8000
Tool clamping	ER11

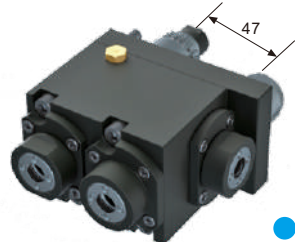

Drilling/milling unit for sub spindle

Product No.	<b>STRB111301</b>
Ref. No.	—
Speed ratio	1:1
RPM Max.	8000
Tool clamping	ER11

## ECAS, SB, SR, SW

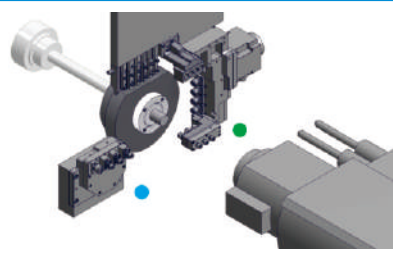

**Cross drilling/milling unit for sub spindle, angle adjustable 15°~45°**

Product No.	<b>STRB316207</b>
Ref. No.	—
Speed ratio	1:1
RPM Max.	6000
Tool clamping	ER16M



**Drill holder for sub spindle** 

Product No.	<b>STRB81Q303</b>
Ref. No.	9D291
Speed ratio	—
RPM Max.	—
Tool clamping	ER20M



**Drill holder for sub spindle** 

Product No.	<b>STRB81Q304</b>
Ref. No.	—
Speed ratio	—
RPM Max.	—
Tool clamping	ER16M

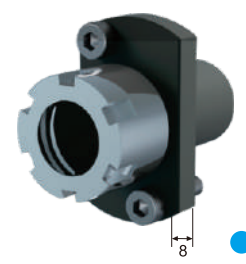

**Drill holder for sub spindle**

Product No.	<b>STRB81Q305</b>
Ref. No.	54121-8L
Speed ratio	—
RPM Max.	—
Tool clamping	ER20M

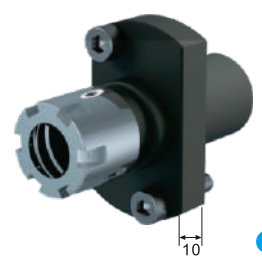

**Drill holder for sub spindle**

Product No.	<b>STRB81Q307</b>
Ref. No.	54121
Speed ratio	—
RPM Max.	—
Tool clamping	ER16M



**Drill holder for sub spindle**

Product No.	<b>STRB81Q309</b>
Ref. No.	—
Speed ratio	—
RPM Max.	—
Tool clamping	ER16M



**Drill holder for sub spindle**

Product No.	<b>STRB81Q312</b>
Ref. No.	—
Speed ratio	—
RPM Max.	—
Tool clamping	ER25UM

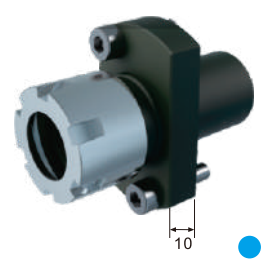

**Drill holder for sub spindle**

Product No.	<b>STRB81Q313</b>
Ref. No.	67122
Speed ratio	—
RPM Max.	—
Tool clamping	ER20M



**Drill holder for sub spindle** 

Product No.	<b>STRB81E202</b>
Ref. No.	0R123
Speed ratio	—
RPM Max.	—
Tool clamping	ER16M



**Drill holder for sub spindle**

Product No.	<b>STRB81E204</b>
Ref. No.	—
Speed ratio	—
RPM Max.	—
Tool clamping	ER20M



**Drill holder for sub spindle**

Product No.	<b>STRB81E205</b>
Ref. No.	—
Speed ratio	—
RPM Max.	—
Tool clamping	ER16M



**Drill holder for sub spindle** 

Product No.	<b>STRB81S301</b>
Ref. No.	10119
Speed ratio	—
RPM Max.	—
Tool clamping	ER20M

## ECAS, SB, SR, SW

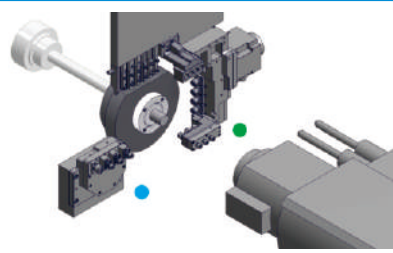

Drill holder for sub spindle

Product No.	<b>STRB81Q101</b>
Ref. No.	69125
Speed ratio	—
RPM Max.	—
Tool clamping	ER11M



Drill holder for sub spindle

Product No.	<b>STRB81Q201</b>
Ref. No.	69124
Speed ratio	—
RPM Max.	—
Tool clamping	ER11M



※ER drill holder not included

Drill holder for sub spindle

Product No.	<b>STRB82Q201</b>
Ref. No.	—
Speed ratio	—
RPM Max.	—
Tool clamping	Ø16



Drill holder for sub spindle

Product No.	<b>STRB81Q105</b>
Ref. No.	—
Speed ratio	—
RPM Max.	—
Tool clamping	ER11M



※ER drill holder not included

Drill holder for sub spindle

Product No.	<b>STRB82Q202</b>
Ref. No.	9D271
Speed ratio	—
RPM Max.	—
Tool clamping	Ø16



Cross drilling/milling unit for sub spindle

Product No.	<b>STRB311206</b>
Ref. No.	10165
Speed ratio	1:1
RPM Max.	6000
Tool clamping	ER11M



Boring bar holder for sub spindle 

Product No.	<b>STRB82EI00</b>
Ref. No.	—
Speed ratio	—
RPM Max.	—
Tool clamping	Ø 1/2 1/4 3/8 5/8 5/16



Boring bar holder for sub spindle 

Product No.	<b>STRB82FI38/STRB82FI12</b>
Ref. No.	—
Speed ratio	—
RPM Max.	—
Tool clamping	Ø 3/8 1/2



Boring bar holder for sub spindle 

Product No.	<b>STRB82Q200/STRB82QI34</b>
Ref. No.	—
Speed ratio	—
RPM Max.	—
Tool clamping	Ø3/4/5/6/8/9/10/12/16/20 Ø3/4

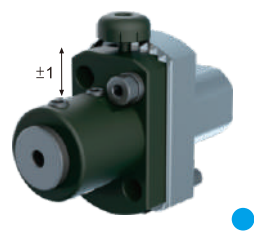

Boring bar holder for sub spindle 

Product No.	<b>STRA22000+COMBAB0000</b>
Ref. No.	—
Speed ratio	—
RPM Max.	—
Tool clamping	Ø3/4/5/6/8/9/10/12/16



Boring bar holder for sub spindle 

Product No.	<b>STRB82E200</b>
Ref. No.	—
Speed ratio	—
RPM Max.	—
Tool clamping	Ø6/8/9/10/12/16



Boring bar holder for sub spindle 

Product No.	<b>STRB82E200</b>
Ref. No.	—
Speed ratio	—
RPM Max.	—
Tool clamping	Ø3 1/8 4 3/16 5

## ECAS, SB, SR, SW

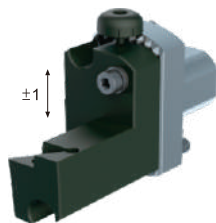
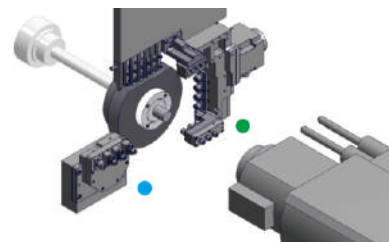

Turning holder for sub spindle ↕

Product No.	<b>STRBA22000+COMBADL550</b>
Ref. No.	—
Speed ratio	—
RPM Max.	—
Tool clamping	DC.T11T3

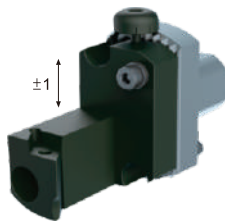

Turning holder for sub spindle ↕

Product No.	<b>STRBA22000+COMBADR550</b>
Ref. No.	—
Speed ratio	—
RPM Max.	—
Tool clamping	DC.T11T3

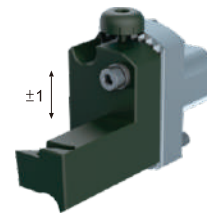

Turning holder for sub spindle ↕

Product No.	<b>STRBA22000+COMBADL350</b>
Ref. No.	—
Speed ratio	—
RPM Max.	—
Tool clamping	VC.T1103



Turning holder for sub spindle

Product No.	<b>STRB912201</b>
Ref. No.	—
Speed ratio	—
RPM Max.	—
Tool clamping	Ø12



Turning holder for sub spindle

Product No.	<b>STRB910202</b>
Ref. No.	—
Speed ratio	—
RPM Max.	—
Tool clamping	□10

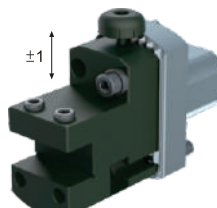

Turning holder for sub spindle ↕

Product No.	<b>STRBA22000+COMBAC1000</b>
Ref. No.	—
Speed ratio	—
RPM Max.	—
Tool clamping	□10



Boring bar holder

Product No.	<b>STRA803310</b>
Ref. No.	—
Speed ratio	—
RPM Max.	—
Tool clamping	Ø22



Turning holder for sub spindle

Product No.	<b>STRB910201</b>
Ref. No.	—
Speed ratio	—
RPM Max.	—
Tool clamping	□10



Turning holder for sub spindle

Product No.	<b>STRB912204</b>
Ref. No.	—
Speed ratio	—
RPM Max.	—
Tool clamping	□12



Cutter width:5mm  
Polygon unit for sub spindle

Product No.	<b>STRB412201</b>
Ref. No.	—
Speed ratio	1:1
RPM Max.	4000
Tool clamping	Ø12.7

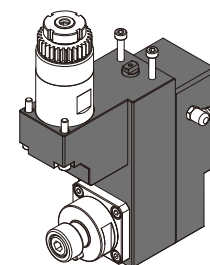

Polygon unit

Product No.	<b>STRA400301</b>
Ref. No.	—
Speed ratio	1:0.6 ↕
RPM Max.	4000
Tool clamping	Ø85 Ø60

# SV32JII, SV12, SV20, ECAS20T

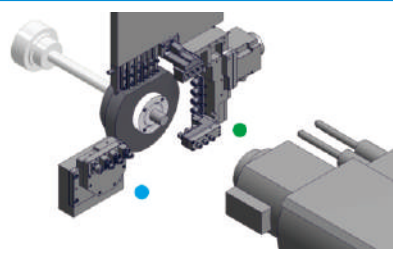

**Axial drilling/milling unit**

Product No.	<b>STVC120201</b>
Ref. No.	22150
Speed ratio	1:1
RPM Max.	6000
Tool clamping	ER20A



**Axial drilling/milling unit**

Product No.	<b>STVC116201</b>
Ref. No.	22150
Speed ratio	1:1
RPM Max.	6000
Tool clamping	ER16A



**2 spindle axial drilling/milling unit**

Product No.	<b>STVC116202</b>
Ref. No.	42151
Speed ratio	1:1
RPM Max.	6000
Tool clamping	ER16A

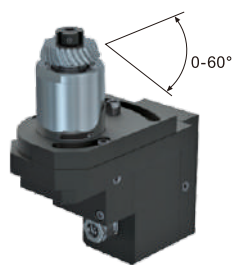

**Universal drilling/milling unit** 

Product No.	<b>STVC2A1201</b>
Ref. No.	42155
Speed ratio	1:1
RPM Max.	6000
Tool clamping	ER11A

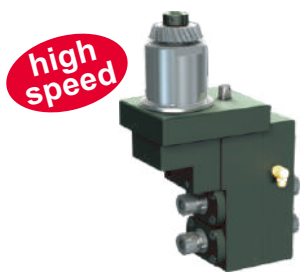

**Radial drilling/milling unit**

Product No.	<b>STVC2B2201</b>
Ref. No.	42159
Speed ratio	1:1.16 
RPM Max.	6000
Tool clamping	ER11M

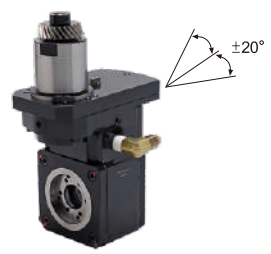

**Thread whirling unit** 

Product No.	<b>STVC545202</b>
Ref. No.	59172
Speed ratio	1:1
RPM Max.	6000
Tool clamping	Utilis no.119287



**Cross drilling/milling unit**

Product No.	<b>STRA108202</b>
Ref. No.	7.071.600
Speed ratio	1:2 
RPM Max.	16000
Tool clamping	ER8M



**Axial drilling/milling unit**

Product No.	<b>STVC111202</b>
Ref. No.	—
Speed ratio	1:2.52 
RPM Max.	15120
Tool clamping	ER8M



※Longitudinally adj. ±1mm

**Turning holder** 

Product No.	<b>STVC916201</b>
Ref. No.	—
Speed ratio	—
RPM Max.	—
Tool clamping	□16

# SV32JII, SV12, SV20, ECAS20T

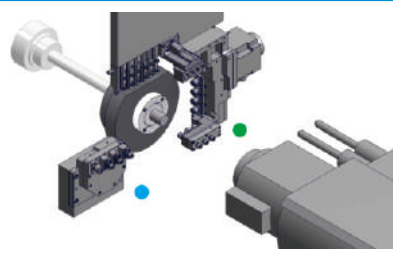

※Longitudinally adj. ±1mm

**Turning holder** 

Product No.	<b>STVC916202</b>
Ref. No.	—
Speed ratio	—
RPM Max.	—
Tool clamping	<input type="checkbox"/> 16



※Longitudinally adj. ±1mm

**Turning holder for sub spindle**

Product No.	<b>STVC916205</b>
Ref. No.	—
Speed ratio	—
RPM Max.	—
Tool clamping	<input type="checkbox"/> 16



※Longitudinally adj. ±1mm

**Turning holder for sub spindle** 

Product No.	<b>STVC916206</b>
Ref. No.	—
Speed ratio	—
RPM Max.	—
Tool clamping	<input type="checkbox"/> 16



**Boring bar holder** 

Product No.	<b>STVC803205</b>
Ref. No.	42111
Speed ratio	—
RPM Max.	—
Tool clamping	Ø32



**2-Station turning holder Ø16**

Product No.	<b>STVC916204</b>
Ref. No.	—
Speed ratio	—
RPM Max.	—
Tool clamping	<input type="checkbox"/> 16

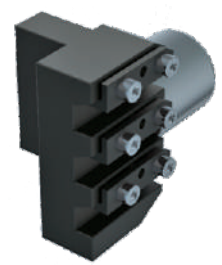

**3-Station turning holder Ø12**

Product No.	<b>STVC912201</b>
Ref. No.	42102
Speed ratio	—
RPM Max.	—
Tool clamping	<input type="checkbox"/> 12



**3-Station turning holder for sub spindle Ø12**

Product No.	<b>STVC912202</b>
Ref. No.	42103
Speed ratio	—
RPM Max.	—
Tool clamping	<input type="checkbox"/> 12

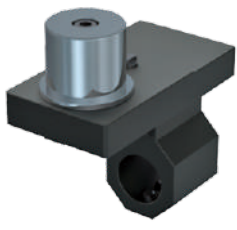

**Boring bar holder**

Product No.	<b>STVC801201</b>
Ref. No.	—
Speed ratio	—
RPM Max.	—
Tool clamping	Ø32



**Boring bar holder**

Product No.	<b>STVC801202</b>
Ref. No.	—
Speed ratio	—
RPM Max.	—
Tool clamping	Ø32

# SV32JII, SV12, SV20, ECAS20T

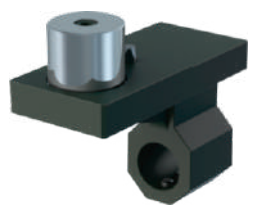
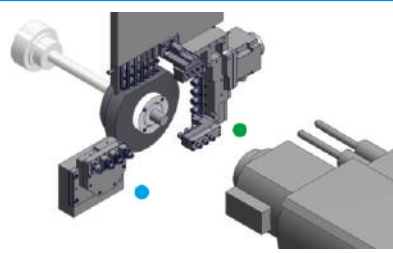

**Boring bar holder**

Product No.	<b>STVC801204</b>
Ref. No.	—
Speed ratio	—
RPM Max.	—
Tool clamping	Ø32



**Boring bar holder**

Product No.	<b>STVC801205</b>
Ref. No.	—
Speed ratio	—
RPM Max.	—
Tool clamping	Ø32

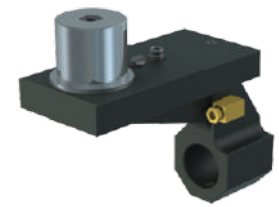

**Boring bar holder**

Product No.	<b>STVC801206</b>
Ref. No.	58113
Speed ratio	—
RPM Max.	—
Tool clamping	Ø32



**Boring bar holder**

Product No.	<b>STVC801207</b>
Ref. No.	22110
Speed ratio	—
RPM Max.	—
Tool clamping	Ø22



**Boring bar holder** 

Product No.	<b>STVC803203</b>
Ref. No.	42112
Speed ratio	—
RPM Max.	—
Tool clamping	Ø22



**Boring bar holder** 

Product No.	<b>STVC803206/STVC803207</b>
Ref. No.	43111
Speed ratio	—
RPM Max.	—
Tool clamping	Ø32 Ø22



**Boring bar holder**

Product No.	<b>STVC802201</b>
Ref. No.	44112
Speed ratio	—
RPM Max.	—
Tool clamping	Ø22

## SV32, ECAS32T, SV-38R

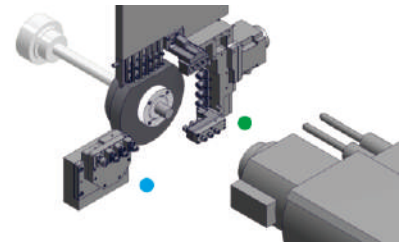

**Axial drilling/milling unit**

Product No.	<b>STVC120301</b>
Ref. No.	58151
Speed ratio	1:1
RPM Max.	6000
Tool clamping	ER20A



**Axial drilling/milling unit**

Product No.	<b>STVC116302</b>
Ref. No.	20150
Speed ratio	1:1
RPM Max.	6000
Tool clamping	ER16A



**Axial drilling/milling unit**

Product No.	<b>STVC125301</b>
Ref. No.	43161
Speed ratio	1:1
RPM Max.	6000
Tool clamping	ER25UM



**Axial drilling/milling unit**

Product No.	<b>STVC111301</b>
Ref. No.	431-52-00
Speed ratio	1:1.67 
RPM Max.	6000
Tool clamping	ER11A



**Axial drilling/milling unit**

Product No.	<b>STVC116301</b>
Ref. No.	43151
Speed ratio	1:1
RPM Max.	6000
Tool clamping	ER16A



**Radial drilling/milling unit**

Product No.	<b>STVC2B2301</b>
Ref. No.	43159
Speed ratio	1:1.16 
RPM Max.	6000
Tool clamping	ER11M



**Radial drilling/milling unit**

Product No.	<b>STVC2B2303</b>
Ref. No.	43159
Speed ratio	1:1
RPM Max.	6000
Tool clamping	ER16M



**Radial drilling/milling unit**

Product No.	<b>STVC2B2304</b>
Ref. No.	43159
Speed ratio	1:1
RPM Max.	6000
Tool clamping	ER16M



**2-spindle drilling/milling unit **

Product No.	<b>STVC2A2303</b>
Ref. No.	19101
Speed ratio	1:1 B axis speed ratio: 80:1 
RPM Max.	5700
Tool clamping	ER16M

# SV32, ECAS32T, SV-38R

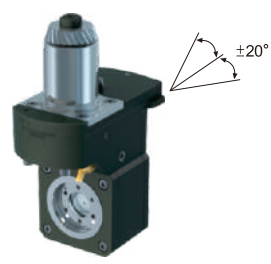
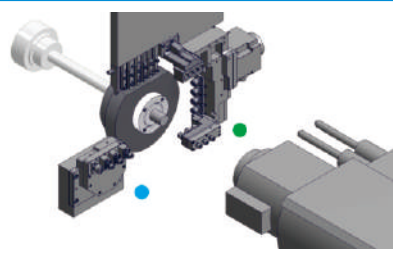

**Thread whirling unit** 

Product No.	<b>STVC545301</b>
Ref. No.	—
Speed ratio	1:1
RPM Max.	6000
Tool clamping	Utilis no.119287



**Universal drilling/milling unit**

Product No.	<b>STVC2A1302</b>
Ref. No.	43155
Speed ratio	1:1
RPM Max.	5700
Tool clamping	ER11A



※Longitudinally adj. ±1mm  
**Turning holder for sub spindle**

Product No.	<b>STVC920303</b>
Ref. No.	43104
Speed ratio	—
RPM Max.	—
Tool clamping	□20



※Longitudinally adj. ±1mm  
**Turning holder for sub spindle**

Product No.	<b>STVC916301</b>
Ref. No.	78171
Speed ratio	—
RPM Max.	—
Tool clamping	□16



※Longitudinally adj. ±1mm  
**Turning holder for sub spindle**

Product No.	<b>STVC920301</b>
Ref. No.	78171
Speed ratio	—
RPM Max.	—
Tool clamping	□20

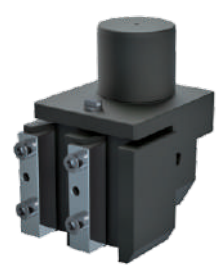

※Longitudinally adj. ±1mm  
**Turning holder for sub spindle**

Product No.	<b>STVC916302</b>
Ref. No.	—
Speed ratio	—
RPM Max.	—
Tool clamping	□16



**2 spindle radial drilling/milling unit**

Product No.	<b>STVC2A2301</b>
Ref. No.	43157
Speed ratio	1:1
RPM Max.	6000
Tool clamping	ER20M



**2 spindle radial drilling/milling unit**

Product No.	<b>STVC2B1302</b>
Ref. No.	20156
Speed ratio	1:1
RPM Max.	6000
Tool clamping	ER16A

## SX38

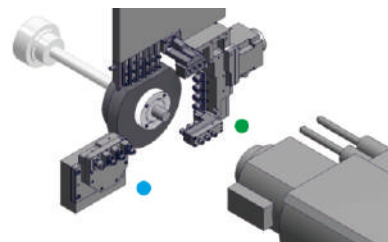

**Drill holder for sub spindle**

Product No.	<b>STXB81E302</b>
Ref. No.	10139
Speed ratio	—
RPM Max.	—
Tool clamping	ER25UM



**Axial drilling/milling unit**

Product No.	<b>STXC120301</b>
Ref. No.	12181
Speed ratio	1:1
RPM Max.	6000
Tool clamping	ER20A



**Boring bar holder**

Product No.	<b>STXC801301</b>
Ref. No.	—
Speed ratio	—
RPM Max.	—
Tool clamping	Ø38



**Universal drilling/milling unit**

Product No.	<b>STXC120302</b>
Ref. No.	—
Speed ratio	1:1
RPM Max.	6000
Tool clamping	ER20M



**Radial drilling/milling unit**

Product No.	<b>STXC2A1301</b>
Ref. No.	—
Speed ratio	1:1
RPM Max.	6000
Tool clamping	ER20NUT



**Double drilling/milling unit**

Product No.	<b>STWA2B1101</b>
Ref. No.	—
Speed ratio	1:1
RPM Max.	12000
Tool clamping	ER11M/ER8M

## SK51



**Radial drilling/milling unit**

Product No.	<b>STKC2A1501</b>
Ref. No.	—
Speed ratio	1:1
RPM Max.	6000
Tool clamping	ER20A

## SP23



**Drilling/milling unit for sub spindle**

Product No.	<b>STPB111201</b>
Ref. No.	—
Speed ratio	1:1
RPM Max.	8000
Tool clamping	ER11



**2-spindle drilling/milling unit**

Product No.	<b>STRA2A3211</b>
Ref. No.	—
Speed ratio	1:1
RPM Max.	6000
Tool clamping	ER16M

## SR38

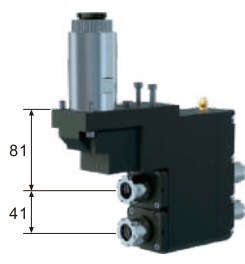
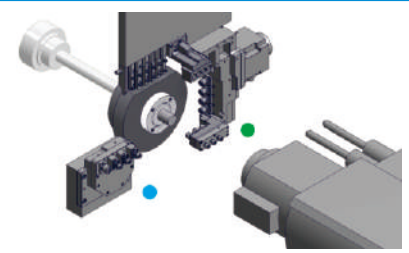

**2-spindle double drilling/milling unit**

Product No.	<b>STRA2B2302</b>
Ref. No.	10169
Speed ratio	1:1
RPM Max.	5000
Tool clamping	ER20M/ER16M



**Drill holder**

Product No.	<b>STRA802303</b>
Ref. No.	10123
Speed ratio	—
RPM Max.	—
Tool clamping	Ø32



**Cross drilling/milling unit**

Product No.	<b>STRA120301</b>
Ref. No.	10168
Speed ratio	1:1
RPM Max.	6000
Tool clamping	ER20M



**Turning holder for sub spindle**

Product No.	<b>STRB955301</b>
Ref. No.	—
Speed ratio	—
RPM Max.	—
Tool clamping	 DC.T11T3

## SL10



**Cross drilling/milling unit**

Product No.	<b>STRA111101</b>
Ref. No.	10152
Speed ratio	1:1
RPM Max.	12000
Tool clamping	ER11M

## BO205

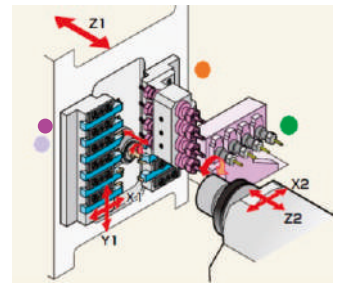

**Tool holder**

Product No.	<b>TSBA0001</b>
Ref. No.	3220-T520
Speed ratio	—
RPM Max.	—
Tool clamping	Ø20



**Cross drilling/milling unit for sub spindle**

Product No.	<b>TSBB311201</b>
Ref. No.	3220-Y7074
Speed ratio	1:1
RPM Max.	8000
Tool clamping	ER11A



**Drilling/milling unit for sub spindle**

Product No.	<b>TSBB116201</b>
Ref. No.	3220-Y7072
Speed ratio	1:1
RPM Max.	8000
Tool clamping	ER16M



**Drill holder for sub spindle** 

Product No.	<b>TSBB81Q202</b>
Ref. No.	D35
Speed ratio	—
RPM Max.	—
Tool clamping	ER11A



**Drill holder for sub spindle**

Product No.	<b>TSBB82Q201</b>
Ref. No.	3220-Y7073
Speed ratio	—
RPM Max.	—
Tool clamping	Ø20

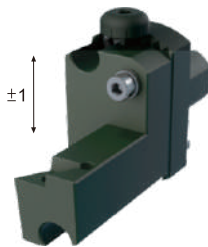

**Turning holder for sub spindle** 

Product No.	<b>TSBBA20000+COMBADL550</b>
Ref. No.	—
Speed ratio	—
RPM Max.	—
Tool clamping	 DC.T11T3



**Air tool holder for sub spindle**

Product No.	<b>TSBB0001</b>
Ref. No.	—
Speed ratio	—
RPM Max.	—
Tool clamping	NR-303



**Turning holder for sub spindle**

Product No.	<b>TSBB912201</b>
Ref. No.	—
Speed ratio	—
RPM Max.	—
Tool clamping	□ 12

## BO265,BO266,BO325,BO326,BO385

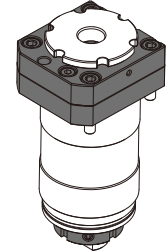
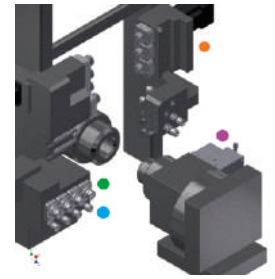

	Cross drilling/milling unit	Cross drilling/milling unit	Cross drilling/milling unit	Cross drilling/milling unit
Product No.	<b>TSBA116301</b>	<b>TSBA120301</b>	<b>TSBA111301</b>	<b>TSBA116306</b>
Ref. No.	3268-T051	3268-T051-ER20	3290-Y670	—
Speed ratio	1:1	1:1	1:2 	1:1
RPM Max.	6000	6000	12000	6000
Tool clamping	ER16A	ER20A	ER11A	M12x1.75

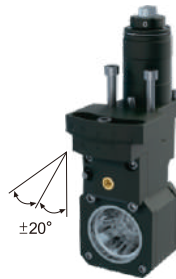

	Cross drilling/milling unit, 2-spindle	Thread whirling unit 	Drilling unit (deep hole)
Product No.	<b>TSBA116304</b>	<b>TSBA545301</b>	<b>TSBA116302</b>
Ref. No.	—	3268-Y450	3290-Y010
Speed ratio	1:1	1:1	1:1
RPM Max.	6000	5000	8000
Tool clamping	ER16AM	Utilis no.119287	ER16A

● It is required to remove the drill holder before mounting.



	Drilling/milling unit	2-spindle drilling/milling unit	2-spindle double drilling/milling unit
Product No.	<b>TSBA2A1301</b>	<b>TSBA2A2304</b>	<b>TSBA2B2303</b>
Ref. No.	—	—	3282-Y901
Speed ratio	1:1	1:1	1:1
RPM Max.	6000	6000	6000
Tool clamping	ER16AM	ER16AM	ER16AM

## BO265, BO266, BO325, BO326, BO385

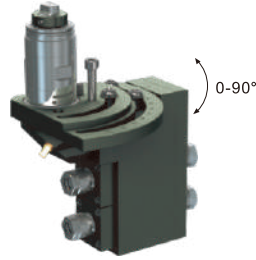
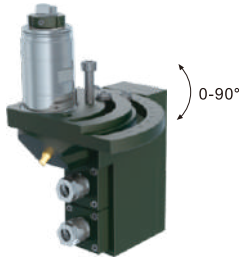
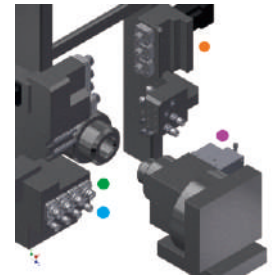

**2-spindle drilling/milling unit** 

Product No.	<b>TSBA2A2301</b>
Ref. No.	3282-Y900
Speed ratio	1:1
RPM Max.	6000
Tool clamping	ER16AM

**2-spindle double drilling/milling unit** 

Product No.	<b>TSBA2B2302</b>
Ref. No.	3282-Y921
Speed ratio	1:1
RPM Max.	6000
Tool clamping	ER16AM

**3-spindle drilling/milling unit**

Product No.	<b>TSBA2A3301</b>
Ref. No.	—
Speed ratio	1:1
RPM Max.	5000
Tool clamping	ER16AM

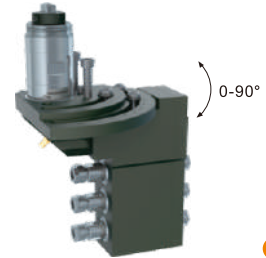
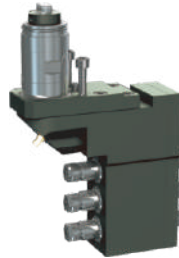
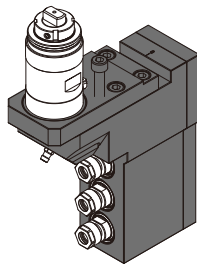

**3-spindle double drilling/milling unit**

Product No.	<b>TSBA2B3305</b>
Ref. No.	—
Speed ratio	1:1
RPM Max.	6000
Tool clamping	ER11A

**3-spindle double drilling/milling unit**

Product No.	<b>TSBA2B3302</b>
Ref. No.	—
Speed ratio	1:1
RPM Max.	6000
Tool clamping	ER11A

**3-spindle double drilling/milling unit** 

Product No.	<b>TSBA2B3301</b>
Ref. No.	—
Speed ratio	1:1
RPM Max.	6000
Tool clamping	ER11A



**high speed**



**Drilling/milling unit for sub spindle**

Product No.	<b>TSBB116301</b>
Ref. No.	3282-Y041
Speed ratio	1:1
RPM Max.	6000
Tool clamping	ER16A

**Drilling/milling unit for sub spindle**

Product No.	<b>TSBB111301</b>
Ref. No.	3290-Y680
Speed ratio	1:2 
RPM Max.	12000
Tool clamping	ER11A

**2-spindle drilling/milling unit for sub spindle**

Product No.	<b>TSBB116302</b>
Ref. No.	—
Speed ratio	1:1
RPM Max.	6000
Tool clamping	ER16AM

**Cross drilling/milling unit for sub spindle**

Product No.	<b>TSBB316301</b>
Ref. No.	3290-Y041
Speed ratio	1:1
RPM Max.	6000
Tool clamping	ER16M

## BO265, BO266, BO325, BO326, BO385

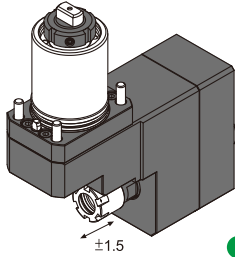
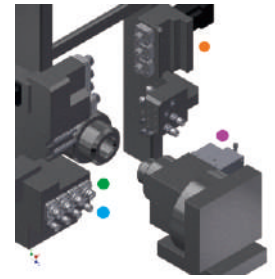

Cross drilling/milling unit for sub spindle

Product No.	<b>TSBB316302</b>
Ref. No.	—
Speed ratio	1:1
RPM Max.	6000
Tool clamping	ER16M



Slotting unit

Product No.	<b>TSBA716301</b>
Ref. No.	—
Speed ratio	2:1 
RPM Max.	3000
Tool clamping	Ø16xØ100



Slotting unit for sub spindle 

Product No.	<b>TSBB712301</b>
Ref. No.	—
Speed ratio	1:1
RPM Max.	3000
Tool clamping	Ø12.7xØ70



Drill holder for sub spindle 

Product No.	<b>TSBB82Q304</b>
Ref. No.	3282-Y212
Speed ratio	—
RPM Max.	—
Tool clamping	Ø25



Drill holder for sub spindle

Product No.	<b>TSBB82Q303</b>
Ref. No.	—
Speed ratio	—
RPM Max.	—
Tool clamping	Ø25

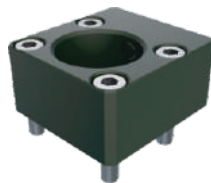

Drill holder for sub spindle

Product No.	<b>TSBB82Q302</b>
Ref. No.	—
Speed ratio	—
RPM Max.	—
Tool clamping	Ø25



Drill holder for sub spindle 

Product No.	<b>TSBB81Q301</b>
Ref. No.	—
Speed ratio	—
RPM Max.	—
Tool clamping	ER20M



Boring bar holder

Product No.	<b>TSBA802301</b>
Ref. No.	—
Speed ratio	—
RPM Max.	—
Tool clamping	Ø25



Turning holder for sub spindle

Product No.	<b>TSBB912301</b>
Ref. No.	—
Speed ratio	—
RPM Max.	—
Tool clamping	□12



Turning holder for sub spindle

Product No.	<b>TSBB910301</b>
Ref. No.	—
Speed ratio	—
RPM Max.	—
Tool clamping	□10



Turning holder for sub spindle

Product No.	<b>TSBB912302</b>
Ref. No.	—
Speed ratio	—
RPM Max.	—
Tool clamping	□12



Boring bar holder for sub spindle 

Product No.	<b>TSBBA42000+COMBAB0000</b>
Ref. No.	—
Speed ratio	—
RPM Max.	—
Tool clamping	Ø3/4/5/6/8/9/10/12/16

## S205, S206

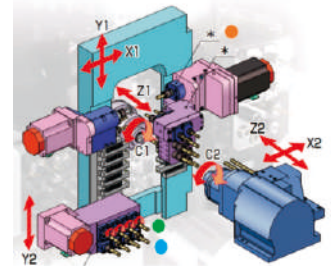

**Cross drilling/milling unit**

Product No.	<b>TSSA111202</b>
Ref. No.	3220-Y7551-0101
Speed ratio	1:4 
RPM Max.	24000
Tool clamping	ER11A



**Cross drilling/milling unit**

Product No.	<b>TSSA116201</b>
Ref. No.	3281-T050
Speed ratio	1:1
RPM Max.	8000
Tool clamping	ER16M



**Cross drilling/milling unit**

Product No.	<b>TSSA116202</b>
Ref. No.	—
Speed ratio	1:1
RPM Max.	8000
Tool clamping	ER16M



**Cross drilling/milling unit**

Product No.	<b>TSSA116203</b>
Ref. No.	—
Speed ratio	2:1 
RPM Max.	3000
Tool clamping	ER16M



**2-spindle double drilling/milling unit**

Product No.	<b>TSSA2B2201</b>
Ref. No.	3281-Y240
Speed ratio	1:1
RPM Max.	8000
Tool clamping	ER16AM/ER11A

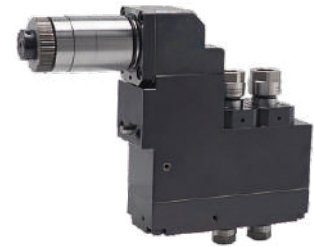

**2-spindle double drilling/milling unit**

Product No.	<b>TSSA2B2203</b>
Ref. No.	—
Speed ratio	1:1
RPM Max.	6000RPM
Tool clamping	ER16AM/ER11A



**3-spindle drilling/milling unit**

Product No.	<b>TSSA2A3201</b>
Ref. No.	—
Speed ratio	1:1
RPM Max.	8000
Tool clamping	ER11A



**3-spindle drilling/milling unit**

Product No.	<b>TSSA2A3204</b>
Ref. No.	—
Speed ratio	1:1
RPM Max.	8000
Tool clamping	ER16AM



**3-spindle double drilling/milling unit**

Product No.	<b>TSSA2B3203</b>
Ref. No.	—
Speed ratio	1:1
RPM Max.	8000
Tool clamping	ER16AM/ER11A

## S205, S206

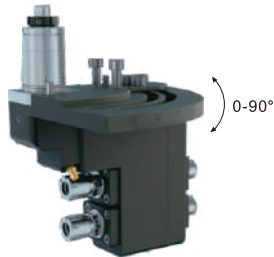
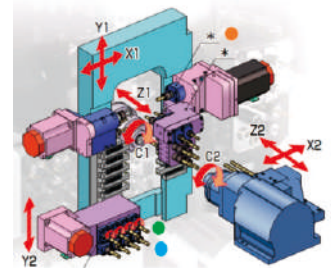

**2-spindle double drilling/milling unit** 

Product No.	<b>TSSA2B2202</b>
Ref. No.	3281-Y280
Speed ratio	1:1
RPM Max.	8000
Tool clamping	ER16AM/ER11A

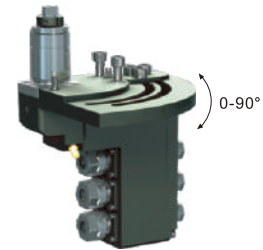

**3-spindle double drilling/milling unit** 

Product No.	<b>TSSA2B3202</b>
Ref. No.	—
Speed ratio	1:1
RPM Max.	8000
Tool clamping	ER16AM/ER11A

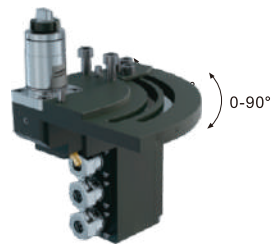

**3-spindle drilling/milling unit** 

Product No.	<b>TSSA2A3203</b>
Ref. No.	—
Speed ratio	1:1
RPM Max.	8000
Tool clamping	ER16AM



**3-spindle double drilling/milling unit**

Product No.	<b>TSSA2B3208</b>
Ref. No.	3281-Z79290-9012
Speed ratio	1:1
RPM Max.	8000
Tool clamping	ER16AM/ER11A



**3-spindle drilling/milling unit** 

Product No.	<b>TSSA2A3205</b>
Ref. No.	—
Speed ratio	1:1
RPM Max.	6000
Tool clamping	ER16AM



**Thread whirling unit** 

Product No.	<b>TSSA545201</b>
Ref. No.	3281-Y450
Speed ratio	1:1
RPM Max.	5000
Utilis no.	119287



**Polygon unit for sub spindle**

Product No.	<b>TSSB412201</b>
Ref. No.	—
Speed ratio	1:1
RPM Max.	4000
Ø	12.7

## S205, S206

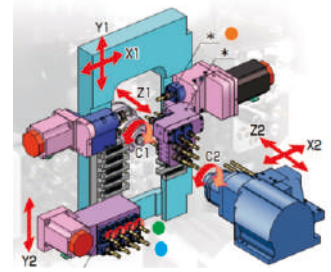

Cross drilling/milling unit for sub spindle

Product No.	<b>TSSB316201</b>
Ref. No.	3281-Y460
Speed ratio	1:1
RPM Max.	6000
Tool clamping	ER16M



Cross drilling/milling unit for sub spindle

Product No.	<b>TSSB316204</b>
Ref. No.	—
Speed ratio	1:1
RPM Max.	6000
Tool clamping	ER16M



Drilling/milling unit for sub spindle

Product No.	<b>TSSB116201</b>
Ref. No.	3281-S080
Speed ratio	1:1
RPM Max.	8000
Tool clamping	ER16M



Drill holder for sub spindle

Product No.	<b>TSSB82Q202/TSSB82Q205</b>
Ref. No.	3281-S060
Speed ratio	—
RPM Max.	—
Tool clamping	Ø20 / Ø16



Drill holder for sub spindle

Product No.	<b>TSSB81Q201</b>
Ref. No.	—
Speed ratio	—
RPM Max.	—
Tool clamping	ER20M



Drill holder for sub spindle

Product No.	<b>TSSB81Q202</b>
Ref. No.	—
Speed ratio	—
RPM Max.	—
Tool clamping	ER16M



Drill holder for sub spindle

Product No.	<b>TSSB82Q203</b>
Ref. No.	—
Speed ratio	—
RPM Max.	—
Tool clamping	Ø20



Drill holder for sub spindle

Product No.	<b>TSSB82Q204</b>
Ref. No.	—
Speed ratio	—
RPM Max.	—
Tool clamping	Ø20



Turning holder for sub spindle

Product No.	<b>TSSB912201</b>
Ref. No.	—
Speed ratio	—
RPM Max.	—
Tool clamping	□12

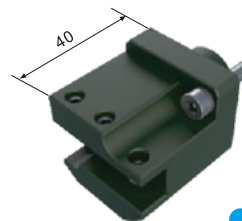

Turning holder for sub spindle

Product No.	<b>TSSB910201</b>
Ref. No.	—
Speed ratio	—
RPM Max.	—
Tool clamping	□10

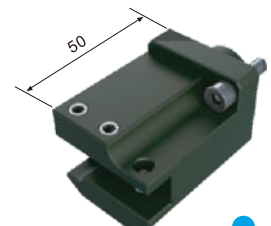

Turning holder for sub spindle

Product No.	<b>TSSB910202</b>
Ref. No.	—
Speed ratio	—
RPM Max.	—
Tool clamping	□10



## M06, M08

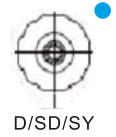
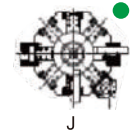
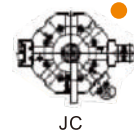

**Axial drilling/milling unit**

Product No.	<b>TSMC125001</b>
Ref. No.	3295-Z92511-0101
Speed ratio	1:1
RPM Max.	6000
Tool clamping	ER25UM



**Radial drilling/milling unit**

Product No.	<b>TSMC2A2001</b>
Ref. No.	3259-Y171
Speed ratio	1:1
RPM Max.	5000
Tool clamping	ER20A



**Turning holder**

Product No.	<b>TSMC925003</b>
Ref. No.	—
Speed ratio	—
RPM Max.	—
Tool clamping	□25



**Turning holder (cut-off)**

Product No.	<b>TSMC925001</b>
Ref. No.	3295-H250
Speed ratio	—
RPM Max.	—
Tool clamping	□25



**Turning holder**

Product No.	<b>TSMC925002</b>
Ref. No.	3295-H210
Speed ratio	—
RPM Max.	—
Tool clamping	□25



**Boring bar holder** 

Product No.	<b>TSMC801002</b>
Ref. No.	—
Speed ratio	—
RPM Max.	—
Tool clamping	Ø32



**Boring bar holder**

Product No.	<b>TSMC801001</b>
Ref. No.	3295-H202
Speed ratio	—
RPM Max.	—
Tool clamping	Ø32



**Boring bar holder**

Product No.	<b>TSMC802001</b>
Ref. No.	—
Speed ratio	—
RPM Max.	—
Tool clamping	Ø25



**Boring bar holder**

Product No.	<b>TSMC802004</b>
Ref. No.	3297-H020
Speed ratio	—
RPM Max.	—
Tool clamping	Ø25



**Boring bar holder** (offset, for main spindle)

Product No.	<b>TSMC802003 / TSMC802005</b>
Ref. No.	3295-H270
Speed ratio	—
RPM Max.	—
Tool clamping	Ø25 / Ø32

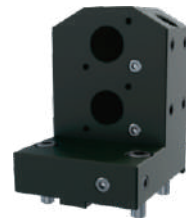

**Boring bar holder** (offset, for sub spindle)

Product No.	<b>TSMC802002</b>
Ref. No.	3295-H280
Speed ratio	—
RPM Max.	—
Tool clamping	Ø25



**Boring bar holder** (offset, for sub spindle)

Product No.	<b>TSMC802007</b>
Ref. No.	—
Speed ratio	—
RPM Max.	—
Tool clamping	Ø25

## M32

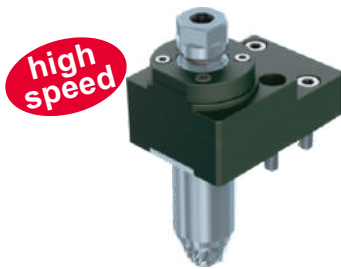

**Axial drilling/milling unit**

Product No.	<b>CTMC116301</b>
Ref. No.	KSC110-2X
Speed ratio	1:2 
RPM Max.	10000
Tool clamping	ER16A



**Axial drilling/milling unit**

Product No.	<b>CTMC116302</b>
Ref. No.	KSC110
Speed ratio	1:1
RPM Max.	5000
Tool clamping	ER16A



**Axial drilling/milling unit** 

Product No.	<b>CTMC116309</b>
Ref. No.	—
Speed ratio	1:1
RPM Max.	5000
Tool clamping	ER16A



**Axial drilling/milling unit**

Product No.	<b>CTMC116314</b>
Ref. No.	—
Speed ratio	1:1
RPM Max.	6000
Tool clamping	ER16A



**Axial drilling/milling unit**

Product No.	<b>CTMC120301</b>
Ref. No.	KSC213
Speed ratio	1:1
RPM Max.	5000
Tool clamping	ER-20A



**Axial drilling/milling unit** 

Product No.	<b>CTMC120303</b>
Ref. No.	KSC213
Speed ratio	1:1
RPM Max.	5000
Tool clamping	ER-20A



**Radial drilling/milling unit**

Product No.	<b>CTMC2A1301</b>
Ref. No.	KSE110
Speed ratio	1:1
RPM Max.	6000
Tool clamping	ER16A



**Radial drilling/milling unit**

Product No.	<b>CTMC2A1302</b>
Ref. No.	KSE310
Speed ratio	1:1
RPM Max.	6000
Tool clamping	ER16A



**Radial drilling/milling unit** 

Product No.	<b>CTMC2A1305</b>
Ref. No.	KSE310
Speed ratio	1:1
RPM Max.	6000
Tool clamping	ER16A



**Radial drilling/milling unit**

Product No.	<b>CTMC2A1307</b>
Ref. No.	KSE113
Speed ratio	1:1
RPM Max.	6000
Tool clamping	ER20A



**Radial drilling/milling unit** 

Product No.	<b>CTMC2A1310</b>
Ref. No.	—
Speed ratio	1:1
RPM Max.	6000
Tool clamping	ER20A

## M32



**3-spindle drilling/milling unit**

Product No.	<b>CTMC2A3301</b>
Ref. No.	GSE-1510
Speed ratio	1:1
RPM Max.	6000
Tool clamping	ER16AM



**Drilling/milling unit**

Product No.	<b>CTMC116303</b>
Ref. No.	KSM110
Speed ratio	1:1
RPM Max.	5000
Tool clamping	ER16A



**Boring bar holder**

Product No.	<b>CTMC801301</b>
Ref. No.	CDF101
Speed ratio	—
RPM Max.	—
Tool clamping	Ø25.4



**Boring bar holder** 

Product No.	<b>CTMC801303</b>
Ref. No.	CDF301
Speed ratio	—
RPM Max.	—
Tool clamping	Ø25.4



**Boring bar holder** 

Product No.	<b>CTMC801304</b>
Ref. No.	CDF-1201
Speed ratio	—
RPM Max.	—
Tool clamping	Ø25.4



**Boring bar holder**

Product No.	<b>CTMC802301</b>
Ref. No.	CDF401
Speed ratio	—
RPM Max.	—
Tool clamping	Ø25.4



**Boring bar holder**

Product No.	<b>CTMC802302</b>
Ref. No.	CDF-1201
Speed ratio	—
RPM Max.	—
Tool clamping	Ø25

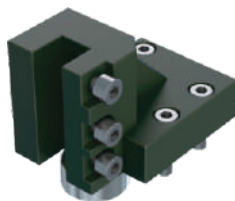

**Turning holder**

Product No.	<b>CTMC916301</b>
Ref. No.	CTF116
Speed ratio	—
RPM Max.	—
Tool clamping	□ 16



**2-Station turning holder** 

Product No.	<b>CTMC916302</b>
Ref. No.	CTF1116
Speed ratio	—
RPM Max.	—
Tool clamping	□ 16

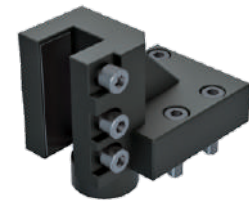

**Turning holder**

Product No.	<b>CTMC919301</b>
Ref. No.	—
Speed ratio	—
RPM Max.	—
Tool clamping	□ 19.05

## M16



**Axial drilling/milling unit**

Product No.	<b>CTMC111101</b>
Ref. No.	MSC106
Speed ratio	1:1
RPM Max.	6000
Tool clamping	ER11A



**Axial drilling/milling unit**

Product No.	<b>CTMC111102</b>
Ref. No.	MSC107BT
Speed ratio	1:1
RPM Max.	6000
Tool clamping	ER11A



**Axial drilling/milling unit**

Product No.	<b>CTMC111103</b>
Ref. No.	MSC407
Speed ratio	1:1
RPM Max.	6000
Tool clamping	ER11A



**Slotting unit**

Product No.	<b>CTMC712101</b>
Ref. No.	MSS345
Speed ratio	1:1
RPM Max.	4000
Tool clamping	Ø12.7xØ70



**Radial drilling/milling unit**

Product No.	<b>CTMC2A1102</b>
Ref. No.	MSE106
Speed ratio	1:1
RPM Max.	4000
Tool clamping	ER11A



**Radial drilling/milling unit**

Product No.	<b>CTMC2A1103</b>
Ref. No.	MST306
Speed ratio	1:1
RPM Max.	3000
Tool clamping	ER11A



**Radial drilling/milling unit**

Product No.	<b>CTMC2A1105</b>
Ref. No.	MSE106-K
Speed ratio	1:1
RPM Max.	6000RPM
Tool clamping	ER11A



**Radial drilling/milling unit**

Product No.	<b>CTMC2A1106</b>
Ref. No.	—
Speed ratio	1:1
RPM Max.	6000RPM
Tool clamping	ER11A

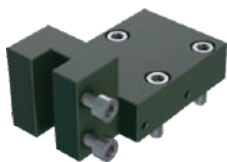

**Turning holder**

Product No.	<b>CTMC910101</b>
Ref. No.	VTF110
Tool clamping	□ 10



**Turning holder (cut-off)**

Product No.	<b>CTMC910102</b>
Ref. No.	VTF1310
Tool clamping	□ 10



**Boring bar holder**

Product No.	<b>CTMC801102</b>
Ref. No.	VDF201
Tool clamping	Ø19.05



**Boring bar holder**

Product No.	<b>CTMC801101</b>
Ref. No.	VDF501
Tool clamping	Ø19.05



**Boring bar holder**

Product No.	<b>CTMC802101</b>
Ref. No.	VDF401
Tool clamping	Ø19.05

## L Series



2-spindle double drilling/milling unit

Product No.	<b>CTLA2B2301</b>
Ref. No.	—
Speed ratio	1:1
RPM Max.	6000
Tool clamping	ER11A



3-spindle drilling/milling unit

Product No.	<b>CTLA2A3301</b>
Ref. No.	BSE307/BSE407/BSE607
Speed ratio	1:1
RPM Max.	6000
Tool clamping	ER11A



3-spindle double drilling/milling unit

Product No.	<b>CTLA2B3302</b>
Ref. No.	BSE507/BSE707
Speed ratio	1:1
RPM Max.	6000
Tool clamping	ER11A



2-spindle double drilling/milling unit

Product No.	<b>CTLA2B2201</b>
Ref. No.	GSE3107
Speed ratio	1:1
RPM Max.	6000
Tool clamping	ER11A

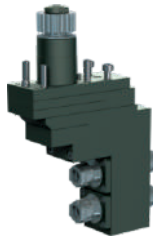

2-spindle double drilling/milling unit

Product No.	<b>CTLA2B2202</b>
Ref. No.	GSE3707
Speed ratio	1:1
RPM Max.	6000
Tool clamping	ER11A



3-spindle double drilling/milling unit

Product No.	<b>CTLA2B3301</b>
Ref. No.	GSE1810
Speed ratio	1:1
RPM Max.	6000
Tool clamping	ER16AM

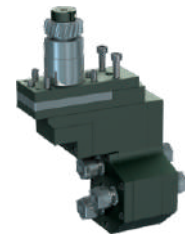

3-spindle double drilling/milling unit

Product No.	<b>CTLA2B3202</b>
Ref. No.	GSE3207
Speed ratio	1:1
RPM Max.	6000
Tool clamping	ER11A



3-spindle double drilling/milling unit

Product No.	<b>CTLA2B3207</b>
Ref. No.	GSE1007
Speed ratio	1:1
RPM Max.	4000
Tool clamping	ER16AM/ER11A



3-spindle double drilling/milling unit

Product No.	<b>CTLA2B3206</b>
Ref. No.	GSE3807
Speed ratio	1:1
RPM Max.	6000
Tool clamping	ER11A

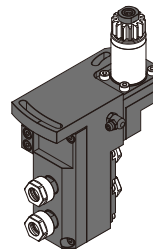

2-spindle double drilling/milling unit

Product No.	<b>CTLA2B2101</b>
Ref. No.	GSE3607
Speed ratio	1:1
RPM Max.	8000
Tool clamping	ER11A



3-spindle double drilling/milling unit

Product No.	<b>CTLA2B3101</b>
Ref. No.	GSE3607
Speed ratio	1:1
RPM Max.	8000
Tool clamping	ER11A

## L Series



**Thread whirling unit** 

Product No.	<b>CTLA545201</b>
Ref. No.	—
Speed ratio	1:1
RPM Max.	6000
Tool clamping	Utilis no.119287



**Drilling/milling unit**

Product No.	<b>CTLA2A3202</b>
Ref. No.	GSE3210
Speed ratio	1:1
RPM Max.	—
Tool clamping	Ø31



**Gear hobbing unit**

Product No.	<b>CTAA608201</b>
Ref. No.	—
Speed ratio	1:1
RPM Max.	3000
Tool clamping	Ø8xØ25x15

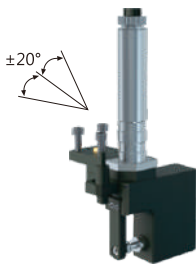

**Gear hobbing unit** 

Product No.	<b>CTLA608201</b>
Ref. No.	—
Speed ratio	1:1
RPM Max.	6000
Tool clamping	滾齒刀 Ø8xØ25x12

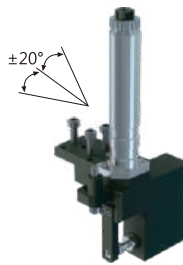

**Gear hobbing unit** 

Product No.	<b>CTLA608202</b>
Ref. No.	—
Speed ratio	1:1
RPM Max.	6000
Tool clamping	滾齒刀 Ø8xØ25x12



**4-spindle double drilling/milling unit**

Product No.	<b>CTLA2B4301</b>
Ref. No.	GSE-2010
Speed ratio	1:1
RPM Max.	6000
Tool clamping	ER16AM



**Drilling/milling unit**

Product No.	<b>CTLA2A1201</b>
Ref. No.	GSE306
Speed ratio	1:1
RPM Max.	6000
Tool clamping	ER11A



**Drilling/milling unit**

Product No.	<b>CTLA2A1205</b>
Ref. No.	—
Speed ratio	1:1
RPM Max.	6000
Tool clamping	ER11A



**Double drilling/milling unit**

Product No.	<b>CTLA2B1302</b>
Ref. No.	—
Speed ratio	1:3 
RPM Max.	15000
Tool clamping	ER11A



**Double drilling/milling unit**

Product No.	<b>CTLA2B1201</b>
Ref. No.	—
Speed ratio	1:1
RPM Max.	6000
Tool clamping	ER11A/ER11M

## L Series



**Double drilling/milling unit**

Product No.	<b>CTLA2B1203</b>
Ref. No.	—
Speed ratio	1:3 
RPM Max.	15000
Tool clamping	ER11A



**Double drilling/milling unit**

Product No.	<b>CTLA2B1301</b>
Ref. No.	—
Speed ratio	1:1
RPM Max.	6000
Tool clamping	ER11A/ER11M



**2-spindle drilling/milling unit**

Product No.	<b>CTLA2A2202</b>
Ref. No.	—
Speed ratio	1:1
RPM Max.	8000
Tool clamping	ER11A



**3-spindle drilling/ milling unit**

Product No.	<b>CTLA2A3201</b>
Ref. No.	GSE910
Speed ratio	1:1
RPM Max.	4000
Tool clamping	ER16M



**3-spindle drilling/ milling unit**

Product No.	<b>CTLA2A3204</b>
Ref. No.	—
Speed ratio	1:1
RPM Max.	8000
Tool clamping	ER11A

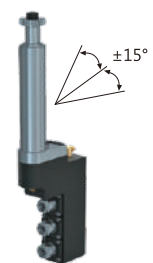

**3-spindle drilling/ milling unit **

Product No.	<b>CTLA2A3205</b>
Ref. No.	GSA107
Speed ratio	1:1
RPM Max.	6000
Tool clamping	ER11A



**3-spindle double drilling/ milling unit**

Product No.	<b>CTLA2B3203</b>
Ref. No.	—
Speed ratio	1:1
RPM Max.	8000
Tool clamping	ER11A/ER11M



**3-spindle double drilling/ milling unit**

Product No.	<b>CTLA2B3204</b>
Ref. No.	GSE1007
Speed ratio	1:1
RPM Max.	4000
Tool clamping	ER11A



**3-spindle double drilling/ milling unit**

Product No.	<b>CTLA2B3205</b>
Ref. No.	GSE1307
Speed ratio	1:1
RPM Max.	4000
Tool clamping	ER11A



**2 spindle axial drilling/ milling unit**

Product No.	<b>CTLA111203</b>
Ref. No.	GSC-1607
Speed ratio	1:1
RPM Max.	4000
Tool clamping	ER11A

## L Series



**Cross drilling/milling unit**

Product No.	<b>CTAA116201</b>
Ref. No.	GSC1310/GSC1110
Speed ratio	1:1
RPM Max.	7000
Tool clamping	ER16AM



**Cross drilling/milling unit**

Product No.	<b>CTAA116202</b>
Ref. No.	GSC1310
Speed ratio	1:1
RPM Max.	7000
Tool clamping	Ø10.5/M10x1.5

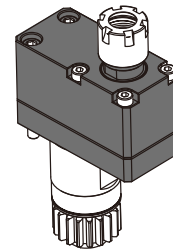

**Axial drilling/milling unit**

Product No.	<b>CTAA116206</b>
Ref. No.	—
Speed ratio	1:1
RPM Max.	6000
Tool clamping	ER16M



**Cross drilling/milling unit**

Product No.	<b>CTLA116201</b>
Ref. No.	GSC1210
Speed ratio	1:1
RPM Max.	8000
Tool clamping	ER16M



**Cross drilling/milling unit**

Product No.	<b>CTLA116202</b>
Ref. No.	GSC510/GSC1010
Speed ratio	1:1
RPM Max.	8000
Tool clamping	ER16A



**Cross drilling/milling unit**

Product No.	<b>CTLA116203</b>
Ref. No.	GSC1210
Speed ratio	1:1
RPM Max.	8000
Tool clamping	ER16



**Cross drilling/milling unit**

Product No.	<b>CTLA116301</b>
Ref. No.	GSC310
Speed ratio	1:1
RPM Max.	8000
Tool clamping	ER16A



**Cross drilling/milling unit**

Product No.	<b>CTLA111202</b>
Ref. No.	GSC907
Speed ratio	1:1
RPM Max.	6000
Tool clamping	ER11A



**Cross drilling/milling unit**

Product No.	<b>CTLA111206</b>
Ref. No.	GSC507-3X
Speed ratio	1:3 
RPM Max.	18000
Tool clamping	ER11A



**Cross drilling/milling unit**

Product No.	<b>CTLA111208</b>
Ref. No.	GSE307
Speed ratio	1:1
RPM Max.	5000
Tool clamping	ER11A

## L Series



**Cross drilling/milling unit**

Product No.	<b>CTAA111201</b>
Ref. No.	GSC1310/GSC1110
Speed ratio	1:4 
RPM Max.	24000
Tool clamping	ER11A



**Cross drilling/milling unit**

Product No.	<b>CTAA116301</b>
Ref. No.	GSC1310
Speed ratio	1:1
RPM Max.	7000
Tool clamping	Ø10.5/M10x1.5



**Cross drilling/milling unit**

Product No.	<b>CTAA120301</b>
Ref. No.	GSC1310
Speed ratio	1:1
RPM Max.	6000
Tool clamping	ER20A



**Cross drilling/milling unit**

Product No.	<b>CTLA111101</b>
Ref. No.	—
Speed ratio	1:1
RPM Max.	8000
Tool clamping	ER11A



**Cross drilling/milling unit**

Product No.	<b>CTLA111303</b>
Ref. No.	—
Speed ratio	1:3 
RPM Max.	18000
Tool clamping	ER11A



**Boring bar holder**

Product No.	<b>CTLA802206</b>
Ref. No.	—
Speed ratio	—
RPM Max.	—
Tool clamping	Ø19.05



**Boring bar holder** 

Product No.	<b>CTLA803208</b>
Ref. No.	—
Speed ratio	—
RPM Max.	—
Tool clamping	Ø19.05



**Boring bar holder**

Product No.	<b>CTLA804101</b>
Ref. No.	—
Speed ratio	—
RPM Max.	—
Tool clamping	Ø19.05



**Boring bar holder**

Product No.	<b>CTLA804301</b>
Ref. No.	—
Speed ratio	—
RPM Max.	—
Tool clamping	Ø19.05



**Drill holder**

Product No.	<b>CTLA804302</b>
Ref. No.	GDF1601
Speed ratio	—
RPM Max.	—
Tool clamping	Ø25



**Drill holder**

Product No.	<b>CTLA804303</b>
Ref. No.	GDF1601
Speed ratio	—
RPM Max.	—
Tool clamping	Ø25.4

## L Series

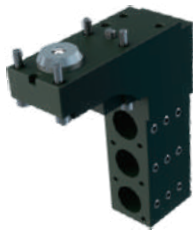

**Boring bar holder**

Product No.	<b>CTLA803305/CTLA803304</b>
Ref. No.	GDF1601
Speed ratio	—
RPM Max.	—
Tool clamping	Ø25.4 / Ø25



**Boring bar holder**

Product No.	<b>CTLA803302</b>
Ref. No.	GDF1207
Speed ratio	—
RPM Max.	—
Tool clamping	Ø19.05



**Boring bar holder**

Product No.	<b>CTLA803303</b>
Ref. No.	—
Speed ratio	—
RPM Max.	—
Tool clamping	Ø20



**Boring bar holder**

Product No.	<b>CTLA802202</b>
Ref. No.	GDF508
Speed ratio	—
RPM Max.	—
Tool clamping	Ø19.05



**Boring bar holder**

Product No.	<b>CTLA801201</b>
Ref. No.	GDF506
Speed ratio	—
RPM Max.	—
Tool clamping	Ø19.05



**Boring bar holder**

Product No.	<b>CTLA802201</b>
Ref. No.	—
Speed ratio	—
RPM Max.	—
Tool clamping	Ø19.05



**Boring bar holder**

Product No.	<b>CTLA803202</b>
Ref. No.	—
Speed ratio	—
RPM Max.	—
Tool clamping	Ø19.05



**Boring bar holder**

Product No.	<b>CTLA803203 / CTLA803210</b>
Ref. No.	GDF506
Speed ratio	—
RPM Max.	—
Tool clamping	Ø19.05 / Ø20



**Boring bar holder**

Product No.	<b>CTLA803204 / CTLA803206</b>
Ref. No.	GDF507
Speed ratio	—
RPM Max.	—
Tool clamping	Ø19.05 / Ø20



**Boring bar holder**

Product No.	<b>CTLA803205 / CTLA803207</b>
Ref. No.	—
Speed ratio	—
RPM Max.	—
Tool clamping	Ø20 / Ø19.05



**Boring bar holder**

Product No.	<b>CTLA803101</b>
Ref. No.	—
Speed ratio	—
RPM Max.	—
Tool clamping	Ø19.05



**Boring bar holder**

Product No.	<b>CTLA803201</b>
Ref. No.	GDF607
Speed ratio	—
RPM Max.	—
Tool clamping	Ø19.05

## L Series



Sub Spindle Boring Bar Holder

Product No.	<b>CTLB82B206~216</b>
Ref. No.	—
Speed ratio	—
RPM Max.	—
Tool clamping	Ø6/8/10/12/16



Sub Spindle Boring Bar Holder

Product No.	<b>CTLB82Q206~216</b>
Ref. No.	—
Speed ratio	—
RPM Max.	—
Tool clamping	Ø6/8/10/12/16



Sub Spindle Boring Bar Holder

Product No.	<b>CTLB82C206~216</b>
Ref. No.	—
Speed ratio	—
RPM Max.	—
Tool clamping	Ø6/8/10/12/16



Drill holder for sub spindle

Product No.	<b>CTLB81Q201</b>
Ref. No.	GDS107
Speed ratio	—
RPM Max.	—
Tool clamping	ER11A



Drill holder for sub spindle

Product No.	<b>CTLB81Q202</b>
Ref. No.	GDS210
Speed ratio	—
RPM Max.	—
Tool clamping	ER16M



Drill holder for sub spindle

Product No.	<b>CTLB81Q203</b>
Ref. No.	GDS210
Speed ratio	—
RPM Max.	—
Tool clamping	ER16M



Drill holder for sub spindle

Product No.	<b>CTLB81Q204</b>
Ref. No.	—
Speed ratio	—
RPM Max.	—
Tool clamping	ER20M



Drill holder for sub spindle

Product No.	<b>CTLB82Q201/CTLB82Q202</b>
Ref. No.	SAU919
Speed ratio	—
RPM Max.	—
Tool clamping	Ø19.05/Ø20



Drill holder for sub spindle

Product No.	<b>CTLB81Q301</b>
Ref. No.	—
Speed ratio	—
RPM Max.	—
Tool clamping	ER16A



Drill holder for sub spindle

Product No.	<b>CTLB82Q300</b>
Ref. No.	SAU825
Speed ratio	—
RPM Max.	—
Tool clamping	Ø25.4/16/25/10/19.05/20



Drill holder for sub spindle

Product No.	<b>CTLB82Q306</b>
Ref. No.	—
Speed ratio	—
RPM Max.	—
Tool clamping	Ø16



Drill holder for sub spindle

Product No.	<b>CTLB81C201</b>
Ref. No.	GDE10254
Speed ratio	—
RPM Max.	—
Tool clamping	ER16M

## L Series



**Turning holder**

Product No.	<b>CTLA900035</b>
Ref. No.	—
Speed ratio	—
RPM Max.	—
Tool clamping	 VC.T1103



**Turning holder**

Product No.	<b>CTLA900055</b>
Ref. No.	GTF3712
Speed ratio	—
RPM Max.	—
Tool clamping	 DC.T1103



**Turning holder**

Product No.	<b>CTLA900060</b>
Ref. No.	—
Speed ratio	—
RPM Max.	—
Tool clamping	TGF32R 175 PR930



**Turning holder**

Product No.	<b>CTLA910101</b>
Ref. No.	—
Speed ratio	—
RPM Max.	—
Tool clamping	<input type="checkbox"/> 10



**Turning holder**

Product No.	<b>CTLA912201</b>
Ref. No.	GTF6312
Speed ratio	—
RPM Max.	—
Tool clamping	<input type="checkbox"/> 12



**Turning holder**

Product No.	<b>CTLA912301</b>
Ref. No.	—
Speed ratio	—
RPM Max.	—
Tool clamping	<input type="checkbox"/> 12



**Turning holder**

Product No.	<b>CTLA913201</b>
Ref. No.	GTF6313
Speed ratio	—
RPM Max.	—
Tool clamping	<input type="checkbox"/> 12.7



**Turning holder for sub spindle**

Product No.	<b>CTLB912201</b>
Ref. No.	—
Speed ratio	—
RPM Max.	—
Tool clamping	<input type="checkbox"/> 12



**Turning holder for sub spindle**

Product No.	<b>CTLB912301</b>
Ref. No.	—
Speed ratio	—
RPM Max.	—
Tool clamping	<input type="checkbox"/> 12

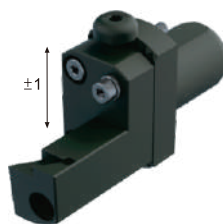

**Turning holder for sub spindle** 

Product No.	<b>CTLBA25000+COMBADL550</b>
Ref. No.	—
Speed ratio	—
RPM Max.	—
Tool clamping	 DC.T11T3

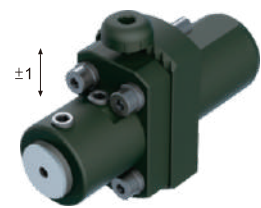

**Boring bar holder for sub spindle** 

Product No.	<b>CTLBA25000+COMBAB0000</b>
Ref. No.	—
Speed ratio	—
RPM Max.	—
Tool clamping	Ø3/4/5/6/8/9/10/12/16

## L Series



Drilling/milling unit for sub spindle 1:2

Product No.	<b>CTLB111203</b>
Ref. No.	MSC-507
Speed ratio	1:2 
RPM Max.	12000
Tool clamping	ER11A



Drilling/milling unit for sub spindle

Product No.	<b>CTLB111202</b>
Ref. No.	GSE3307/GSE3507/MSC507
Speed ratio	1:1
RPM Max.	8000
Tool clamping	ER11A



Drilling/milling unit for sub spindle

Product No.	<b>CTLB111206</b>
Ref. No.	MSC507
Speed ratio	1:4 
RPM Max.	24000
Tool clamping	ER11A



Drilling/milling unit for sub spindle

Product No.	<b>CTLB116201</b>
Ref. No.	MSC512
Speed ratio	1:1
RPM Max.	8000
Tool clamping	ER16A

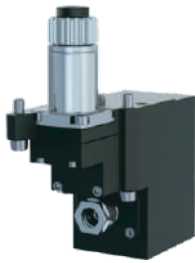

Cross drilling/milling unit for sub spindle

Product No.	<b>CTLB311205</b>
Ref. No.	GSS1330/GSS1430/GSS1530
Speed ratio	1:1
RPM Max.	6000
Tool clamping	ER11A

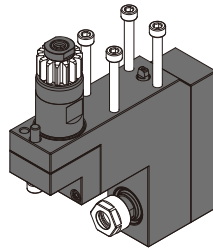

Cross drilling/milling unit for sub spindle

Product No.	<b>CTLB311207</b>
Ref. No.	—
Speed ratio	1:1
RPM Max.	5000
Tool clamping	ER11A



Cross drilling/milling unit for sub spindle

Product No.	<b>CTLB316202</b>
Ref. No.	GSC1507
Speed ratio	1:1
RPM Max.	5000
Tool clamping	ER16A



Cross drilling/milling unit for sub spindle

Product No.	<b>CTLB316301</b>
Ref. No.	GSE1910
Speed ratio	1:1
RPM Max.	6000
Tool clamping	ER16AM



Slotting unit for sub spindle

Product No.	<b>CTLB700201</b>
Ref. No.	—
Speed ratio	1:1
RPM Max.	4000
Tool clamping	Ø6/ 8 /12.7xØ35



Idler shaft

Product No.	<b>CTLA100000</b>
Ref. No.	—
Speed ratio	—
RPM Max.	—
Tool clamping	—



Idler shaft

Product No.	<b>CTLA100001</b>
Ref. No.	—
Speed ratio	—
RPM Max.	—
Tool clamping	—

## A Series

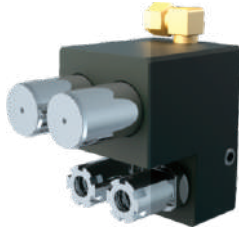

**Drill holder (deep hole)**

Product No.	<b>CTAA802201</b>
Ref. No.	—
Speed ratio	—
RPM Max.	—
Tool clamping	ER16M



**3-spindle double drilling/milling unit**

Product No.	<b>CTAA2B3301</b>
Ref. No.	GSE1710
Speed ratio	1:1
RPM Max.	4000
Tool clamping	ER16AM



**Drilling/milling unit for sub spindle**

Product No.	<b>CTLB111208</b>
Ref. No.	—
Speed ratio	1:1
RPM Max.	6000
Tool clamping	ER11A



※Option: cutter

**Polygon unit**

Product No.	<b>CTAA400201</b>
Ref. No.	—
Speed ratio	1:1
RPM Max.	5000
Tool clamping	—



**Boring bar holder**

Product No.	<b>CTAA803201</b>
Ref. No.	—
Speed ratio	—
RPM Max.	—
Tool clamping	Ø20



**Boring bar holder**

Product No.	<b>CTAA803202</b>
Ref. No.	—
Speed ratio	—
RPM Max.	—
Tool clamping	Ø19.05



**Gear hobbing unit**

Product No.	<b>CTAA608202</b>
Ref. No.	—
Speed ratio	—
RPM Max.	3000
Tool clamping	Ø25xØ8x15



**Drill holder for sub spindle** 

Product No.	<b>CTAB81Q201</b>
Ref. No.	—
Speed ratio	—
RPM Max.	—
Tool clamping	ER16M



**Sub Spindle Boring Bar Holder**

Product No.	<b>CTAB82Q201/CTAB82Q202</b>
Ref. No.	—
Speed ratio	—
RPM Max.	—
Tool clamping	Ø 25.4/25

## ■ BND,BNE,BNJ,ABX

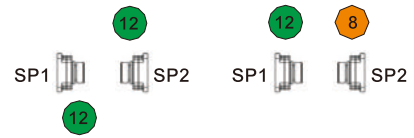

**Axial drilling/milling unit**

Product No.	<b>BM45MI1A0101</b>
Ref. No.	2X785600
Speed ratio	1:1
RPM Max.	6000
Tool clamping	ER20A



**Axial drilling/milling unit**

Product No.	<b>BM45MI1A0106</b>
Ref. No.	1X783000
Speed ratio	1:1
RPM Max.	6000
Tool clamping	ER20A



**Axial drilling/milling unit**

Product No.	<b>BM45MI1A0202</b>
Ref. No.	—
Speed ratio	1:1
RPM Max.	6000
Tool clamping	ER16A



**Radial drilling/milling unit**  25bar

Product No.	<b>BM45MI1B0101</b>
Ref. No.	2X785600/2W785550
Speed ratio	1:1
RPM Max.	6000
Tool clamping	ER20A



**Axial drilling/milling unit**

Product No.	<b>BM38MI1A0103</b>
Ref. No.	DV70B001
Speed ratio	1:1
RPM Max.	6000
Tool clamping	ER16A

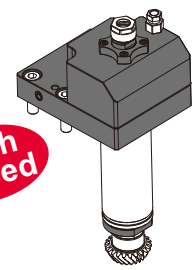

**Axial drilling/milling unit**

Product No.	<b>BM38MI1A0108</b>
Ref. No.	DV70B001
Speed ratio	1:3 
RPM Max.	9000
Tool clamping	ER11A



**Radial drilling/milling unit**

Product No.	<b>BM38MI1B0104</b>
Ref. No.	DV70A000
Speed ratio	1:1
RPM Max.	6000
Tool clamping	ER16A

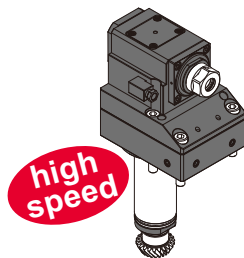

**Radial drilling/milling unit**

Product No.	<b>BM38MI1B0109</b>
Ref. No.	DV70A000-3X
Speed ratio	1:3 
RPM Max.	9000
Tool clamping	ER16A



**Axial drilling/milling unit**

Product No.	<b>BM45MI1A0102</b>
Ref. No.	2K700000
Speed ratio	1:1
RPM Max.	6000
Tool clamping	ER20A



**Axial drilling/milling unit**

Product No.	<b>BM45MI1A0108</b>
Ref. No.	—
Speed ratio	1:1
RPM Max.	6000
Tool clamping	ER32UM

## BND, BNE, BNJ, ABX



**Axial drilling/milling unit**

Product No.	<b>BM45MI1A0109</b>
Ref. No.	2X785600
Speed ratio	1:3.05 ⬆
RPM Max.	18300
Tool clamping	ER20A



25bar

**Radial drilling/milling unit**

Product No.	<b>BM45MI1B0102</b>
Ref. No.	2K701000
Speed ratio	1:1
RPM Max.	4000
Tool clamping	ER20A

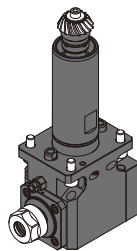

**Double Radial drilling/milling unit**

Product No.	<b>BM45MI1B0108</b>
Ref. No.	2K703000
Speed ratio	1:1
RPM Max.	4000
Tool clamping	ER20A/ER11A



**Radial drilling/milling unit**

Product No.	<b>BM45MI1B0202</b>
Ref. No.	—
Speed ratio	1:1
RPM Max.	6000
Tool clamping	ER16M



**Universal drilling/milling unit**

Product No.	<b>BM45MI1H1802</b>
Ref. No.	—
Speed ratio	1:1
RPM Max.	6000
Tool clamping	ER20M



**Axial drilling/milling unit**

Product No.	<b>BM54MI1A0101</b>
Ref. No.	—
Speed ratio	1:1
RPM Max.	6000
Tool clamping	ER32UM



25bar

**Radial drilling/milling unit**

Product No.	<b>BM54MI1B0104</b>
Ref. No.	—
Speed ratio	1:1
RPM Max.	6000
Tool clamping	ER32UM



25bar

**Radial drilling/milling unit**

Product No.	<b>BM54MI1B0102</b>
Ref. No.	—
Speed ratio	1:1
RPM Max.	6000
Tool clamping	ER25UM

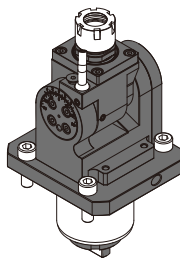

**Universal drilling/milling unit**

Product No.	<b>BM54MI1H1802</b>
Ref. No.	—
Speed ratio	1:1
RPM Max.	6000
Tool clamping	ER20M



**Boring bar holder**

Product No.	<b>BM45MI2D1302</b>
Ref. No.	—
Speed ratio	—
RPM Max.	—
Tool clamping	Ø32

## ■ BND,BNE,BNJ,ABX

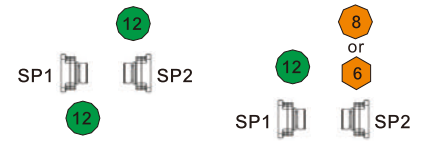

**Turning holder**

Product No.	<b>BM45MI2A2001</b>
Ref. No.	1X780100
Speed ratio	—
RPM Max.	—
Tool clamping	□20



**Turning holder**

Product No.	<b>BM45MI2A2005/BM45MI2A2008</b>
Ref. No.	1X780200
Speed ratio	—
RPM Max.	—
Tool clamping	□20 □19.05



**Turning holder**

Product No.	<b>BM45MI2B2001/BM45MI2B2003</b>
Ref. No.	1X784600
Speed ratio	—
RPM Max.	—
Tool clamping	□20 □19.05



**Turning holder**

Product No.	<b>BM45MI2B2002/BM45MI2B2004</b>
Ref. No.	1X784100
Speed ratio	—
RPM Max.	—
Tool clamping	□20 □19.05



**Multiple holder**

Product No.	<b>BM45MI2E0001/BM45MI2E0002</b>
Ref. No.	1X780500
Speed ratio	—
RPM Max.	—
Tool clamping	□20 Ø25 □19.05 Ø25.4



**Boring bar holder** 

Product No.	<b>BM45MI2D2501</b>
Ref. No.	1X780600
Speed ratio	—
RPM Max.	—
Tool clamping	Ø25



**Turning holder**

Product No.	<b>BM38MI2A2006</b>
Ref. No.	—
Speed ratio	—
RPM Max.	—
Tool clamping	□20

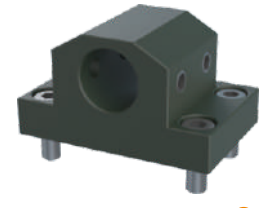

**Boring bar holder**

Product No.	<b>BM38MI2D1501</b>
Ref. No.	2K749001
Speed ratio	—
RPM Max.	—
Tool clamping	Ø25



**Boring bar holder for sub spindle**

Product No.	<b>BM38MI2D2503</b>
Ref. No.	DV73B000
Speed ratio	—
RPM Max.	—
Tool clamping	Ø25



**Turning holder**

Product No.	<b>BM45MI2A2003</b>
Ref. No.	6M780100
Speed ratio	—
RPM Max.	—
Tool clamping	—



**Turning holder (cut-off)**

Product No.	<b>BM45MI2A2004</b>
Ref. No.	2X782401
Speed ratio	—
RPM Max.	—
Tool clamping	□20



**Turning holder (Cut-off)**

Product No.	<b>BM45MI2A2006</b>
Ref. No.	2X782401
Speed ratio	—
RPM Max.	—
Tool clamping	□20x12

## BNA



Cross drilling/milling unit

Product No.	<b>BM38MI1A0101</b>
Ref. No.	CG70A000
Speed ratio	1:1
RPM Max.	8000
Tool clamping	ER16A



Cross drilling/milling unit

Product No.	<b>BM38MI1A0104</b>
Ref. No.	CG70J000/CG70A000
Speed ratio	1:1
RPM Max.	8000
Tool clamping	ER16A



Axial drilling/milling unit

Product No.	<b>BM38MI1A0106</b>
Ref. No.	CG70J000
Speed ratio	1:1
RPM Max.	8000
Tool clamping	ER20A

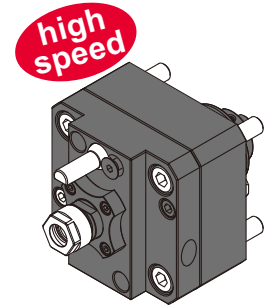

Cross drilling/milling unit

Product No.	<b>BM38MI1A0107</b>
Ref. No.	CG70A000
Speed ratio	1:3 
RPM Max.	24000
Tool clamping	ER11A



Axial drilling/milling unit

Product No.	<b>BM38MI1A0201</b>
Ref. No.	CL70A000/CL70C000
Speed ratio	1:1.66 
RPM Max.	6000
Tool clamping	ER11A



Radial drilling/milling unit

Product No.	<b>BM38MI1B0101</b>
Ref. No.	CG70D000
Speed ratio	1:1
RPM Max.	6000
Tool clamping	ER16A



Radial drilling/milling unit  25bar

Product No.	<b>BM38MI1B0102</b>
Ref. No.	CG70C000
Speed ratio	1:1
RPM Max.	6000
Tool clamping	ER16A



Radial drilling/milling unit

Product No.	<b>BM38MI1B0105</b>
Ref. No.	CG70C000/CG70L000
Speed ratio	1:1
RPM Max.	6000
Tool clamping	ER16A



Double Radial drilling/milling unit

Product No.	<b>BM38MI1B0106</b>
Ref. No.	CG70E000
Speed ratio	1:1
RPM Max.	6000
Tool clamping	ER16-NUT



Radial drilling/milling unit

Product No.	<b>BM38MI1B0201</b>
Ref. No.	CG70E000/CG70N000
Speed ratio	1:1
RPM Max.	6000
Tool clamping	ER16A



Radial drilling/milling unit

Product No.	<b>BM38MI1B0202</b>
Ref. No.	—
Speed ratio	1:1
RPM Max.	6000
Tool clamping	ER11(内螺帽)



Radial drilling/milling unit

Product No.	<b>BM38MI1B0205</b>
Ref. No.	—
Speed ratio	1:1
RPM Max.	6000
Tool clamping	ER16A

## BNA

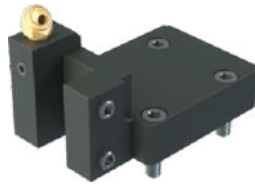
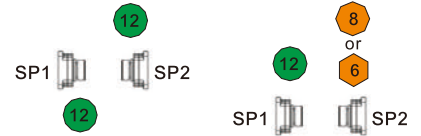

**Turning holder (Cut-off)**

Product No.	<b>BM38MI2A2001</b>
Ref. No.	CG73C000
Speed ratio	—
RPM Max.	—
Tool clamping	□20



**Turning holder**

Product No.	<b>BM38MI2A2003</b>
Ref. No.	CG73M000
Speed ratio	—
RPM Max.	—
Tool clamping	□20



**Turning holder**

Product No.	<b>BM38MI2B2001</b>
Ref. No.	CL73A001
Speed ratio	—
RPM Max.	—
Tool clamping	□20



**Turning holder**

Product No.	<b>BM38MI2B2002</b>
Ref. No.	CG73L000
Speed ratio	—
RPM Max.	—
Tool clamping	□20



**Boring bar holder**

Product No.	<b>BM38MI2D2501</b>
Ref. No.	CG73P000
Speed ratio	—
RPM Max.	—
Tool clamping	Ø25



**Boring bar holder**

Product No.	<b>BM38MI2D2504</b>
Ref. No.	7S780400
Speed ratio	—
RPM Max.	—
Tool clamping	Ø25



**Boring bar holder**

Product No.	<b>BM38MI2D3501</b>
Ref. No.	CG73E000
Speed ratio	—
RPM Max.	—
Tool clamping	Ø25



**Boring bar holder**

Product No.	<b>BM38MI2D4501</b>
Ref. No.	CL73B000
Speed ratio	—
RPM Max.	—
Tool clamping	Ø25

## BNC



**Turning holder**

Product No.	<b>BM38MI2A2005</b>
Ref. No.	7S780100
Speed ratio	—
RPM Max.	—
Tool clamping	□20



**Turning holder**

Product No.	<b>BM38MI2A2004</b>
Ref. No.	7S780200
Speed ratio	—
RPM Max.	—
Tool clamping	□20

## BNX



**Radial drilling/milling unit**

Product No.	<b>BM45MI1B0203</b>
Ref. No.	CG70E000
Speed ratio	1:1
RPM Max.	6000
Tool clamping	ER16NUT

## CB



**Gear hobbing unit**

Product No.	<b>CCBA610301</b>
Ref. No.	—
Speed ratio	1:1
RPM Max.	6000
Tool clamping	Ø10xØ30x20



**Cross drilling/milling unit, 2-spindle**

Product No.	<b>CCBA116301</b>
Ref. No.	—
Speed ratio	1:1
RPM Max.	6000
Tool clamping	ER16A

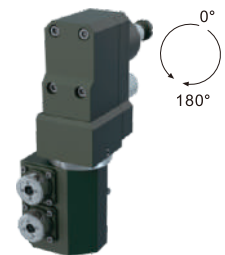

**2-spindle drilling/milling unit**

Product No.	<b>CCBA2A2301</b>
Ref. No.	—
Speed ratio	1:1
RPM Max.	6000
Tool clamping	ER11



**4-spindle double drilling/milling unit**

Product No.	<b>CCBA2B4301</b>
Ref. No.	—
Speed ratio	1:2 ↕
RPM Max.	6000
Tool clamping	ER20M*4/ER16M*4+Ø25*5



**5-spindle double drilling/milling unit**

Product No.	<b>CCBA2B5301</b>
Ref. No.	—
Speed ratio	1:2 ↕
RPM Max.	6000
Tool clamping	ER16A*5/ER11A*5+Ø25*5



**5-spindle double drilling/milling unit**

Product No.	<b>CCBA2B5302</b>
Ref. No.	—
Speed ratio	1:1
RPM Max.	6000
Tool clamping	ER16A*5/ER11A*5+Ø25*5



**Slotting unit for sub spindle**

Product No.	<b>CCBB700301</b>
Ref. No.	—
Speed ratio	1:0.75 ↕
RPM Max.	3000
Tool clamping	Ø6/12.7xØ45



**Cross drilling/milling unit for sub spindle**

Product No.	<b>CCBB316301</b>
Ref. No.	—
Speed ratio	1:1
RPM Max.	5000
Tool clamping	ER16



**Cross drilling/milling unit, 2-spindle**

Product No.	<b>CCBA111302</b>
Ref. No.	—
Speed ratio	1:1
RPM Max.	6000
Tool clamping	ER11A

## CB



Turning holder for sub spindle

Product No.	<b>CCBB912301</b>
Ref. No.	—
Speed ratio	—
RPM Max.	—
Tool clamping	□12



Turning holder for sub spindle

Product No.	<b>CCBB912302</b>
Ref. No.	—
Speed ratio	—
RPM Max.	—
Tool clamping	□12



Turning holder for sub spindle

Product No.	<b>CCBB916301</b>
Ref. No.	—
Speed ratio	—
RPM Max.	—
Tool clamping	□16



Drill holder for sub spindle

Product No.	<b>CCBB81Q302</b>
Ref. No.	—
Speed ratio	—
RPM Max.	—
Tool clamping	ER20A



Boring bar holder for sub spindle

Product No.	<b>CCBB82Q302</b>
Ref. No.	—
Speed ratio	—
RPM Max.	—
Tool clamping	Ø12



Drill holder for sub spindle

Product No.	<b>CCBB82Q301</b>
Ref. No.	—
Speed ratio	—
RPM Max.	—
Tool clamping	Ø25

## SY2-45



Drilling/milling unit

Product No.	<b>CCSA2B3401</b>
Ref. No.	—
Speed ratio	1:1
RPM Max.	6000
Tool clamping	ER20M

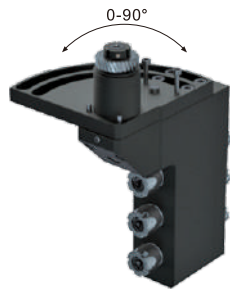

Drilling/milling unit, Angle adj. 0~90°

Product No.	<b>CCSA2B3402</b>
Ref. No.	—
Speed ratio	1:1
RPM Max.	6000
Tool clamping	ER20M



Cross drilling/milling unit for sub spindle

Product No.	<b>CCSB320401</b>
Ref. No.	—
Speed ratio	1:1.026 ⬆
RPM Max.	6000
Tool clamping	ER20M



Slotting unit for sub spindle

Product No.	<b>CCSB712401</b>
Ref. No.	—
Speed ratio	1:1.026 ⬆
RPM Max.	6000
Tool clamping	Ø12.7xØ70

## CT-52YM



**Axial drilling/milling unit**

Product No.	<b>BM65NK1A0101</b>
Ref. No.	—
Speed ratio	1:1
RPM Max.	6000
Tool clamping	ER32UM



**Axial drilling/milling unit**

Product No.	<b>BM65NK1A0102</b>
Ref. No.	—
Speed ratio	1:1
RPM Max.	6000
Tool clamping	ER32UM

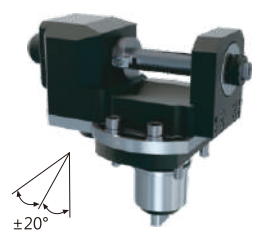

**Gear hobbing unit**

Product No.	<b>BM65NK1F2221</b>
Ref. No.	—
Speed ratio	2:1
RPM Max.	3000
Tool clamping	Ø22.225xØ80x80



**Radial drilling/milling unit**

Product No.	<b>BM65NK1B0101</b>
Ref. No.	—
Speed ratio	1:1
RPM Max.	6000
Tool clamping	ER32UM



**Radial drilling/milling unit**

Product No.	<b>BM65NK1B0102</b>
Ref. No.	—
Speed ratio	1:1
RPM Max.	6000
Tool clamping	ER32UM



**Universal drilling/milling unit**

Product No.	<b>BM65NK1H1801</b>
Ref. No.	—
Speed ratio	1:1
RPM Max.	6000
Tool clamping	ER20

## CY2-52

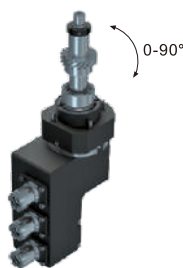

**Drilling/milling unit**

Product No.	<b>CCYA2A3502</b>
Ref. No.	—
Speed ratio	1:1
RPM Max.	6000
Tool clamping	ER16M



**Drilling/milling unit**

Product No.	<b>CCYA2A3503</b>
Ref. No.	—
Speed ratio	1:1
RPM Max.	6000
Tool clamping	ER16M

## SY2-42E



**Cross drilling/milling unit for sub spindle**

Product No.	<b>CCSB316401</b>
Ref. No.	—
Speed ratio	1:1
RPM Max.	6000
Tool clamping	ER16A

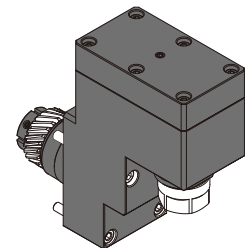

**Cross drilling/milling unit for sub spindle**

Product No.	<b>CCSB316402</b>
Ref. No.	—
Speed ratio	1:1
RPM Max.	6000
Tool clamping	ER16A



## YB Series



**Tool holder**

Product No.  
Ref. No.  
Speed ratio  
RPM Max.  
Tool clamping

**NUYA0001**

—  
—  
—  
—



**Cross drilling/milling unit**

**NUYA120201**

—  
1:1  
6000  
ER20M

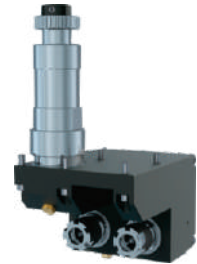

**2-spindle drilling/milling unit**

**NUYA2A2301**

—  
1:1  
6000  
ER16M



**Drill holder for sub spindle (deep hole)**

Product No.  
Ref. No.  
Speed ratio  
RPM Max.  
Tool clamping

**NUYB81Q305**

—  
—  
—  
ER20M



**Drilling/milling unit for sub spindle**

**NUYB111301**

—  
1:1  
6000  
ER11M

## Other



**3-spindle drilling/milling unit**

Product No.  
Ref. No.  
Speed ratio  
RPM Max.  
Tool clamping

**NUJA2A3201**

—  
1:1  
6000  
ER11A



**Cross drilling/milling unit** ⚙️

**NUBA108201**

—  
1:1  
6000  
ER8M

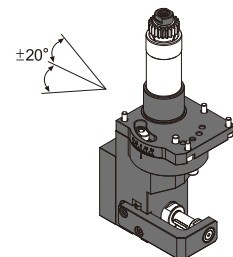

**Gear hobbing unit** ⚙️

**NUJA610201**

—  
1:1  
4000  
∅ 10

## SB Series



4-spindle drilling/milling unit

Product No.	<b>NUSA2A4101</b>
Ref. No.	—
Speed ratio	1:1
RPM Max.	6000
Tool clamping	ER11



Cross drilling/milling unit, 3-spindle

Product No.	<b>NUSA111102</b>
Ref. No.	—
Speed ratio	1:1
RPM Max.	6000
Tool clamping	ER11M



2-spindle drilling/milling unit

Product No.	<b>NUSA2A2102</b>
Ref. No.	—
Speed ratio	1:1
RPM Max.	6000
Tool clamping	ER11



Cross drilling/milling unit, 2-spindle

Product No.	<b>NUSA116101</b>
Ref. No.	—
Speed ratio	1.59:1
RPM Max.	6000
Tool clamping	ER16M



Cross drilling/milling unit, 3-spindle

Product No.	<b>NUSA116102</b>
Ref. No.	—
Speed ratio	1:1
RPM Max.	6000
Tool clamping	ER16M

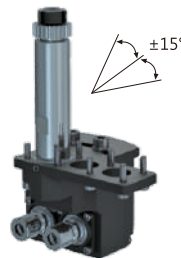

Drilling/milling unit, Angle adj. 0~90°

Product No.	<b>NUSA2A2101</b>
Ref. No.	—
Speed ratio	1:1
RPM Max.	6000
Tool clamping	ER11M

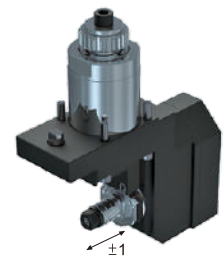

Slotting unit for sub spindle

Product No.	<b>NUSB706101</b>
Ref. No.	—
Speed ratio	1:0.55
RPM Max.	4000
Tool clamping	Ø5/Ø6/Ø8/Ø10/Ø12.7/Ø13

## UB Series



Drill holder for sub spindle

Product No.	<b>NUUB81Q202</b>
Ref. No.	—
Speed ratio	—
RPM Max.	—
Tool clamping	ER16M



Drill holder for sub spindle

Product No.	<b>NUUB81Q204</b>
Ref. No.	—
Speed ratio	—
RPM Max.	—
Tool clamping	ER16M



Sub Spindle Boring Bar Holder

Product No.	<b>NUUB82A200</b>
Ref. No.	—
Speed ratio	—
RPM Max.	—
Tool clamping	Ø6/8/10/12

## UB Series



**Cross drilling/milling unit**

Product No.	<b>NUUA116204</b>
Ref. No.	—
Speed ratio	1:1
RPM Max.	6000
Tool clamping	ER16M



**Cross drilling/milling unit**

Product No.	<b>NUUA116201</b>
Ref. No.	—
Speed ratio	1:1
RPM Max.	6000
Tool clamping	ER16M



**Idler shaft**

Product No.	<b>NUUA100000</b>
Ref. No.	—
Speed ratio	—
RPM Max.	—
Tool clamping	—



**3-spindle drilling/milling unit**

Product No.	<b>NUUA2A3202</b>
Ref. No.	—
Speed ratio	1:1
RPM Max.	6000
Tool clamping	ER11M



**Sub Spindle Boring Bar Holder**

Product No.	<b>NUUB82Q206</b>
Ref. No.	—
Speed ratio	—
RPM Max.	—
Tool clamping	Ø6



**Drilling/milling unit**

Product No.	<b>NUJA2A1201</b>
Ref. No.	—
Speed ratio	1:1
RPM Max.	6000
Tool clamping	ER11M



**Axial drilling/milling unit**

Product No.	<b>NUUA116202</b>
Ref. No.	—
Speed ratio	1:1
RPM Max.	6000
Tool clamping	ER16M

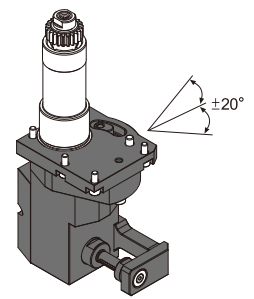

**Gear hobbing unit** 

Product No.	<b>NUBA606201/NUBA608201</b>
Ref. No.	—
Speed ratio	1:1
RPM Max.	4000
Tool clamping	Ø6 Ø8

## Back Processing Static Tool Holder Shaft: Ø22, Ø23



**Drill holder for sub spindle**

Product No.	<b>NUUB81Q201/NUUB81Q203</b>
Ref. No.	—
Speed ratio	—
RPM Max.	Ø22 / Ø23
Tool clamping	ER16M



**Drill holder for sub spindle**

Product No.	<b>NUYB81Q301/NUYB81Q302</b>
Ref. No.	—
Speed ratio	—
RPM Max.	Ø22 / Ø23
Tool clamping	ER16M



**Drill holder for sub spindle (deep hole)**

Product No.	<b>NUYB81Q304/NUYB81Q303</b>
Ref. No.	—
Speed ratio	—
RPM Max.	Ø22 / Ø23
Tool clamping	ER16M



**Drill holder for sub spindle**

Product No.	<b>KDA22016025MA/KDA23016025M</b>
Ref. No.	—
Speed ratio	—
RPM Max.	Ø22 / Ø23
Tool clamping	ER16M



**Turning holder for sub spindle**

Product No.	<b>NUUB910201/NUUB910202</b>
Ref. No.	—
Speed ratio	—
RPM Max.	Ø22 / Ø23
Tool clamping	□10

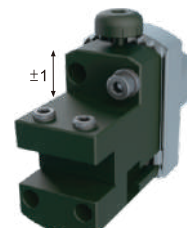

**Turning holder for sub spindle** 

Product No.	<b>NUUBA22000+COMBAC1000</b>
Ref. No.	—
Speed ratio	—
RPM Max.	Ø22
Tool clamping	□10

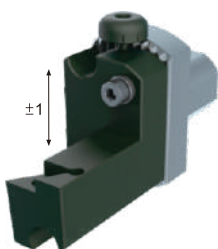

**Turning holder for sub spindle** 

Product No.	<b>NUUBA22000+COMBADL550</b>
Ref. No.	—
Speed ratio	—
RPM Max.	Ø22
Tool clamping	 DC..11T3

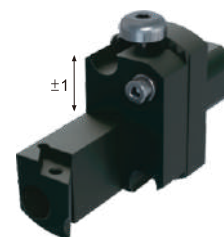

**Turning holder for sub spindle** 

Product No.	<b>NUUBA22000+COMBADR550</b>
Ref. No.	—
Speed ratio	—
RPM Max.	Ø22
Tool clamping	 DC.11T3

## XD20H



**Cross drilling/milling unit**

Product No.	<b>HWDA116201</b>
Ref. No.	—
Speed ratio	1:1
RPM Max.	8000
Tool clamping	ER16A



**Cross drilling/milling unit**

Product No.	<b>HWDA116203</b>
Ref. No.	—
Speed ratio	1:1
RPM Max.	8000
Tool clamping	ER16M



**2-spindle drilling/milling unit**

Product No.	<b>HWDA2A2201</b>
Ref. No.	—
Speed ratio	1:1
RPM Max.	6000
Tool clamping	ER16M

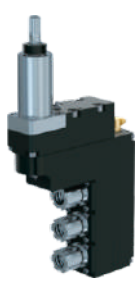

**3-spindle drilling/milling unit**

Product No.	<b>HWDA2A3201</b>
Ref. No.	—
Speed ratio	1:1
RPM Max.	6000
Tool clamping	ER16M



**3-spindle double drilling/milling unit**

Product No.	<b>HWDA2B3202</b>
Ref. No.	—
Speed ratio	1:1
RPM Max.	6000
Tool clamping	ER16M/ER11M

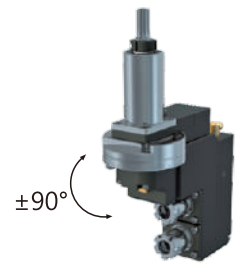

**Drilling/milling unit, Angle adj. 0~90°**

Product No.	<b>HWDA2A2202</b>
Ref. No.	—
Speed ratio	1:1
RPM Max.	8000
Tool clamping	ER16M

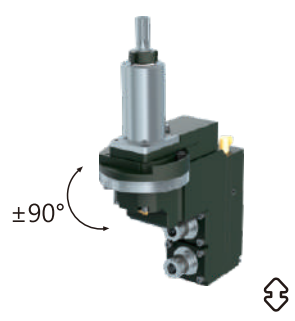

**2-spindle drilling/milling unit**

Product No.	<b>HWDA2A2203</b>
Ref. No.	—
Speed ratio	1:1
RPM Max.	8000
Tool clamping	ER11M

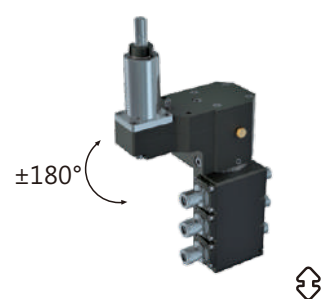

**3-spindle double drilling/milling unit**

Product No.	<b>HWDA2B3209</b>
Ref. No.	HWX591300
Speed ratio	1:1
RPM Max.	8000
Tool clamping	ER11M/ER8M

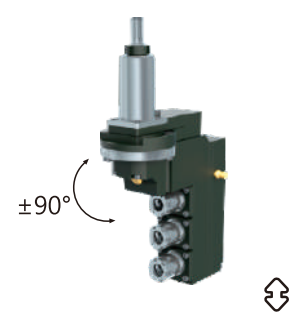

**3-spindle drilling/milling unit**

Product No.	<b>HWDA2A3202</b>
Ref. No.	—
Speed ratio	1:1
RPM Max.	8000
Tool clamping	ER16M

## XD20H

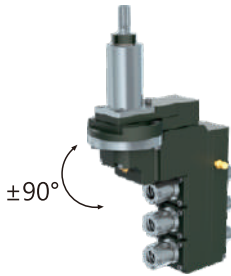

3-spindle double drilling/milling unit

Product No.	<b>HWDA2B3204</b>
Ref. No.	—
Speed ratio	1:1
RPM Max.	8000
Tool clamping	ER16M/ER11M



Drilling/milling unit for sub spindle

Product No.	<b>HWDB116201</b>
Ref. No.	—
Speed ratio	1:1
RPM Max.	8000
Tool clamping	ER16A



Cross drilling/milling unit for sub spindle

Product No.	<b>HWDB311201</b>
Ref. No.	—
Speed ratio	1:0.55
RPM Max.	4000
Tool clamping	ER11A



Cross drilling/milling unit for sub spindle

Product No.	<b>HWDB311202</b>
Ref. No.	—
Speed ratio	1:1
RPM Max.	4000
Tool clamping	ER11A



Cross drilling/milling unit for sub spindle

Product No.	<b>HWDB316202</b>
Ref. No.	—
Speed ratio	1:0.55
RPM Max.	4000
Tool clamping	ER16A



Slotting unit for sub spindle

Product No.	<b>HWDB700201</b>
Ref. No.	—
Speed ratio	1:0.55
RPM Max.	4000
Tool clamping	鋸片 Ø5/6/8/10/12.7/13xØ50



Thread whirling unit

Product No.	<b>HWDA545205</b>
Ref. No.	—
Speed ratio	1:1
RPM Max.	6000
Tool clamping	Utilis no.119287



Boring bar holder

Product No.	<b>HWDA803201</b>
Ref. No.	—
Speed ratio	—
RPM Max.	—
Tool clamping	Ø25



Boring bar holder

Product No.	<b>HWDA803202</b>
Ref. No.	—
Speed ratio	—
RPM Max.	—
Tool clamping	Ø25



Turning holder

Product No.	<b>HWDA912201</b>
Ref. No.	—
Speed ratio	—
RPM Max.	—
Tool clamping	□12



Turning holder

Product No.	<b>HWDA912202</b>
Ref. No.	—
Speed ratio	—
RPM Max.	—
Tool clamping	□12

## XD20HII



**Cross drilling/milling unit**

Product No.	<b>HWDA116202</b>
Ref. No.	—
Speed ratio	1:1
RPM Max.	6000
Tool clamping	ER16A



**Cross drilling/milling unit**

Product No.	<b>HWDA116204</b>
Ref. No.	—
Speed ratio	1:3
RPM Max.	18000
Tool clamping	ER11A



**3-spindle drilling/milling unit**

Product No.	<b>HWDA2A3203</b>
Ref. No.	—
Speed ratio	1:1
RPM Max.	6000
Tool clamping	ER16M



**3-spindle double drilling/milling unit**

Product No.	<b>HWDA2B3207</b>
Ref. No.	—
Speed ratio	1:1
RPM Max.	6000
Tool clamping	ER16M/ER11M

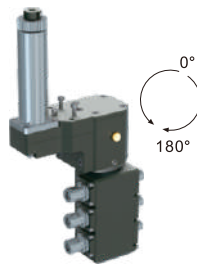

**3-spindle double drilling/milling unit**

Product No.	<b>HWDA2B3208</b>
Ref. No.	—
Speed ratio	1:1
RPM Max.	8000
Tool clamping	ER11M/ER8M



**Slotting unit for sub spindle**

Product No.	<b>HWDB700202</b>
Ref. No.	—
Speed ratio	1:0.55
RPM Max.	4000
Tool clamping	Ø6/12.7/13xØ50

## XD12H



**Slotting unit for sub spindle**

Product No.	<b>HWDB700101</b>
Ref. No.	—
Speed ratio	1:0.55
RPM Max.	4000
Tool clamping	Ø5/6/8/10/12.7/13xØ50

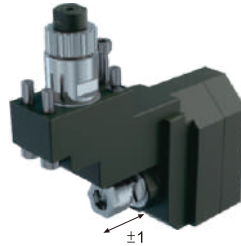

**Cross drilling/milling unit for sub spindle**

Product No.	<b>HWDB311101</b>
Ref. No.	—
Speed ratio	1:0.55
RPM Max.	4000
Tool clamping	ER11A



**Drilling/milling unit for sub spindle**

Product No.	<b>HWDB111101</b>
Ref. No.	—
Speed ratio	1:1
RPM Max.	6000
Tool clamping	ER11

## XD32H

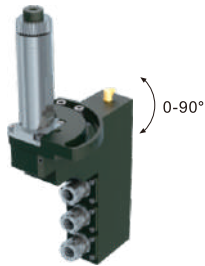

**3-spindle drilling/milling unit** 

Product No.	<b>HWDA2A3301</b>
Ref. No.	—
Speed ratio	1:1
RPM Max.	6000
Tool clamping	ER16M



**3-spindle drilling/milling unit**

Product No.	<b>HWDA2A3302</b>
Ref. No.	—
Speed ratio	1:1
RPM Max.	6000
Tool clamping	ER16M



**3-spindle double drilling/milling unit**

Product No.	<b>HWDA2B3302</b>
Ref. No.	—
Speed ratio	1:1
RPM Max.	6000
Tool clamping	ER16M/ER11M



**Cross drilling/milling unit for sub spindle** 

Product No.	<b>HWDB316301</b>
Ref. No.	—
Speed ratio	1:0.77 
RPM Max.	4000
Tool clamping	ER16A



**Slotting unit for sub spindle** 

Product No.	<b>HWDB700301</b>
Ref. No.	—
Speed ratio	1:0.77 
RPM Max.	4000
Tool clamping	Ø5/6/8/10/12.7/13xØ60



**Slotting unit for sub spindle** 

Product No.	<b>HWDB700302</b>
Ref. No.	—
Speed ratio	1:0.55 
RPM Max.	4000
Tool clamping	Ø5/6/8/10/12.7/13xØ50

## XD-20IIV



**Slotting unit for sub spindle** 

Product No.	<b>HWDB700202</b>
Ref. No.	—
Speed ratio	1:0.55 
RPM Max.	4000
Tool clamping	Ø6/8/10/12.7/13xØ50



**Cross drilling/milling unit for sub spindle** 

Product No.	<b>HWDB316203</b>
Ref. No.	—
Speed ratio	1:0.55 
RPM Max.	4000
Tool clamping	ER16A

## XD-20II/26II



**Drilling/milling unit for sub spindle**

Product No.	<b>HWDB116202</b>
Ref. No.	—
Speed ratio	1:1
RPM Max.	8000
Tool clamping	ER16A

## XD-35N



**3-spindle drilling/milling unit**

Product No.	<b>HWDA2A3303</b>
Ref. No.	—
Speed ratio	1:1
RPM Max.	6000
Tool clamping	ER16M



**3-spindle double drilling/milling unit**

Product No.	<b>HWDA2B3304</b>
Ref. No.	—
Speed ratio	1:1
RPM Max.	6000
Tool clamping	ER16M/ER11M

## XD-07



**Polygon unit**

Product No.	<b>HWDA400101</b>
Ref. No.	—
Speed ratio	1:1
RPM Max.	4000
Tool clamping	Ø8



**Polygon unit**

Product No.	<b>HWDA411101</b>
Ref. No.	—
Speed ratio	1:1
RPM Max.	4000
Tool clamping	ER11M

## XD-20V

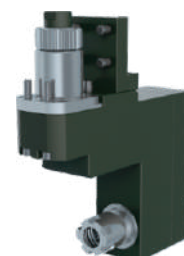

**Cross drilling/milling unit for sub spindle**

Product No.	<b>HWDB316201</b>
Ref. No.	—
Speed ratio	1:1
RPM Max.	6000
Tool clamping	ER16M

## XD-10



**Drill holder for sub spindle**

Product No.	<b>HWDB81Q104</b>
Ref. No.	—
Speed ratio	—
RPM Max.	—
Tool clamping	ER16M



**Sub Spindle Boring Bar Holder**

Product No.	<b>HWDB82Q017</b>
Ref. No.	—
Speed ratio	—
RPM Max.	—
Tool clamping	Ø16

## XD-26H



**Cross drilling/milling unit**

Product No.	<b>HWDA111202</b>
Ref. No.	—
Speed ratio	1:3 ⚙️
RPM Max.	18000
Tool clamping	ER11A

## JSL-20RB/RBY



3-spindle double drilling/milling unit

Product No.	JSSA2B3401
Ref. No.	—
Speed ratio	1:1
RPM Max.	6000
Tool clamping	ER16M/ER11M

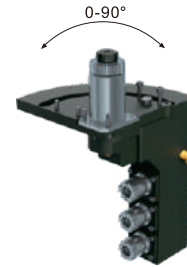

3-spindle double drilling/milling unit 

Product No.	JSSA2B3402
Ref. No.	—
Speed ratio	1:1
RPM Max.	6000
Tool clamping	ER16M/ER11M

## JSL-42RB/RBY

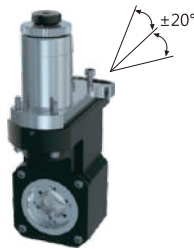

Thread whirling unit 

Product No.	JSSA545401
Ref. No.	—
Speed ratio	1:1
RPM Max.	6000
Tool clamping	Utilis no.119287



Slotting unit

Product No.	JSSA712401
Ref. No.	—
Speed ratio	1:0.374 
RPM Max.	4000
Tool clamping	Ø12.7xØ100



Slotting unit

Product No.	JSSA725401
Ref. No.	—
Speed ratio	1:0.374 
RPM Max.	4000
Tool clamping	Ø25.4xØ110

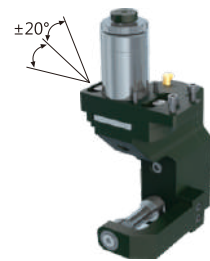

Gear hobbing unit 

Product No.	JSSA616401
Ref. No.	—
Speed ratio	1:1
RPM Max.	6000
Tool clamping	Ø16xØ40x42



Drilling/milling unit for sub spindle

Product No.	JSSB120401
Ref. No.	—
Speed ratio	1:1
RPM Max.	8000
Tool clamping	ER20M



Cross drilling/milling unit for sub spindle 

Product No.	JSSB316401
Ref. No.	—
Speed ratio	1:1
RPM Max.	4000
Tool clamping	ER16A



Cross drilling/milling unit for sub spindle

Product No.	JSSB316402
Ref. No.	—
Speed ratio	1:1
RPM Max.	6000
Tool clamping	ER16M



Cross drilling/milling unit for sub spindle

Product No.	JSSB316403
Ref. No.	—
Speed ratio	1:1
RPM Max.	6000
Tool clamping	ER16M

## BMT-45



**Cross drilling/milling unit**

Product No.	<b>BM45DS1A0101</b>
Ref. No.	—
Speed ratio	1:1
RPM Max.	6000
Tool clamping	ER25UM



**Radial drilling/milling unit**  25bar

Product No.	<b>BM45DS1B0102</b>
Ref. No.	—
Speed ratio	1:1
RPM Max.	6000
Tool clamping	ER25UM

## BMT-55



**Radial drilling/milling unit**  30bar

Product No.	<b>BM55DS1B0101</b>
Ref. No.	—
Speed ratio	1:1
RPM Max.	6000
Tool clamping	ER25UM



**Radial drilling/milling unit**

Product No.	<b>BM55DS1B0102</b>
Ref. No.	—
Speed ratio	1:1
RPM Max.	6000
Tool clamping	ER25UM



**Axial drilling/milling unit**

Product No.	<b>BM55DS1A0101</b>
Ref. No.	—
Speed ratio	1:1
RPM Max.	6000
Tool clamping	ER25UM



**Turning holder (cut-off)**

Product No.	<b>BM55DS2A2501</b>
Ref. No.	—
Speed ratio	—
RPM Max.	—
Tool clamping	□25



**Turning holder**

Product No.	<b>BM55DS2A2503</b>
Ref. No.	—
Speed ratio	—
RPM Max.	—
Tool clamping	□25



**Turning holder**

Product No.	<b>BM55DS2A2502</b>
Ref. No.	—
Speed ratio	—
RPM Max.	—
Tool clamping	□25



**Boring bar holder**

Product No.	<b>BM55DS2D1501</b>
Ref. No.	—
Speed ratio	—
RPM Max.	—
Tool clamping	Ø25

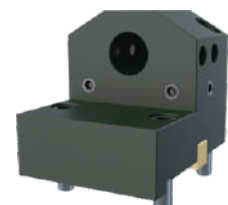

**Boring bar holder**

Product No.	<b>BM55DS2D1502</b>
Ref. No.	—
Speed ratio	—
RPM Max.	—
Tool clamping	Ø25

## ■ BMT-65



**Cross drilling/milling unit**  25bar

Product No.	<b>BM65DS1A0102</b>
Ref. No.	—
Speed ratio	1:1
RPM Max.	6000
Tool clamping	ER32



**Radial drilling/milling unit**  25bar

Product No.	<b>BM65DS1B0104</b>
Ref. No.	—
Speed ratio	1:1
RPM Max.	6000
Tool clamping	ER32



**Radial drilling/milling unit**  25bar

Product No.	<b>BM65DS1B0101</b>
Ref. No.	—
Speed ratio	1:1
RPM Max.	6000
Tool clamping	ER32



**Double Radial drilling/milling unit**

Product No.	<b>BM65DS1B0105</b>
Ref. No.	—
Speed ratio	1:1
RPM Max.	6000
Tool clamping	ER32UM/ER20M

## PUMA ST35G/GS



**3-spindle double drilling/milling unit**

Product No.	<b>DSTA2B3301</b>
Ref. No.	—
Speed ratio	1:1
RPM Max.	6000
Tool clamping	ER16M/ER11M

## WT-150,AS-200(BMT-55)



**Axial drilling/milling unit**

Product No.	<b>BM55NK1A0101</b>
Ref. No.	AC1310
Speed ratio	1:1
RPM Max.	6000
Tool clamping	ER25UM



**Radial drilling/milling unit**

Product No.	<b>BM55NK1B0101</b>
Ref. No.	Z1514
Speed ratio	1:1
RPM Max.	6000
Tool clamping	ER25UM



**Radial drilling/milling unit**

Product No.	<b>BM55NK1B0105</b>
Ref. No.	—
Speed ratio	1:2 
RPM Max.	12000RPM
Tool clamping	ER16A



**Universal drilling/milling unit**

Product No.	<b>BM55NK1H1801</b>
Ref. No.	—
Speed ratio	1:1
RPM Max.	6000RPM
Tool clamping	ER20M



**Turning holder**

Product No.	<b>BM55NK2A2501</b>
Ref. No.	—
Speed ratio	—
RPM Max.	—
Tool clamping	<input type="checkbox"/> 25



**Turning holder (cut-off)**

Product No.	<b>BM55NK2A2001</b>
Ref. No.	—
Speed ratio	—
RPM Max.	—
Tool clamping	<input type="checkbox"/> 20

## WT-100,WY-100(BMT-44)



**Axial drilling/milling unit**

Product No.	<b>BM44NK1A0104</b>
Ref. No.	—
Speed ratio	1:1
RPM Max.	6000
Tool clamping	ER25UM



**Radial drilling/milling unit**

Product No.	<b>BM44NK1B0105</b>
Ref. No.	—
Speed ratio	1:1
RPM Max.	6000
Tool clamping	ER25UM



**Radial drilling/milling unit**

Product No.	<b>BM44NK1B0104</b>
Ref. No.	—
Speed ratio	1:1
RPM Max.	6000
Tool clamping	ER20A

## WT-100, WY-100 (BMT-44)



**Axial drilling/milling unit**

Product No.	<b>BM44NK1A0103</b>
Ref. No.	—
Speed ratio	1:1
RPM Max.	6000
Tool clamping	ER20A



**Axial drilling/milling unit**  25bar

Product No.	<b>BM44NK1A0105</b>
Ref. No.	—
Speed ratio	1:1
RPM Max.	6000
Tool clamping	ER20A



**Axial drilling/milling unit**

Product No.	<b>BM44NK1A0106</b>
Ref. No.	—
Speed ratio	1:0.5 
RPM Max.	3000
Tool clamping	ER20A



**Radial drilling/milling unit**

Product No.	<b>BM44NK1B0106</b>
Ref. No.	—
Speed ratio	1:1
RPM Max.	6000
Tool clamping	ER32UM



**Universal drilling/milling unit**

Product No.	<b>BM44NK1H1801</b>
Ref. No.	—
Speed ratio	1:1
RPM Max.	6000
Tool clamping	ER20M



**Double side turning holder 20x20**

Product No.	<b>BM44NK2B2002</b>
Ref. No.	—
Speed ratio	—
RPM Max.	—
Tool clamping	□20



**Turning holder**

Product No.	<b>BM44NK2B2001</b>
Ref. No.	—
Speed ratio	—
RPM Max.	—
Tool clamping	□20



**Boring bar holder** 

Product No.	<b>BM44NK2D1301</b>
Ref. No.	—
Speed ratio	—
RPM Max.	—
Tool clamping	Ø 32



**Boring bar holder**

Product No.	<b>BM44NK2D1501</b>
Ref. No.	—
Speed ratio	—
RPM Max.	—
Tool clamping	Ø 25



**Boring bar holder**

Product No.	<b>BM44NK2D2501</b>
Ref. No.	—
Speed ratio	—
RPM Max.	—
Tool clamping	Ø 25



**Turning holder (cut-off)**

Product No.	<b>BM44NK2A2001</b>
Ref. No.	C21470
Speed ratio	—
RPM Max.	—
Tool clamping	□20

## GLS1500Y/GTW1500Y

### SW32/SW42



**Sub Spindle Boring Bar Holder**

Product No.	<b>GDTB82Q220</b>
Ref. No.	—
Speed ratio	—
RPM Max.	—
Tool clamping	Ø20



**Sub Spindle Boring Bar Holder**

Product No.	<b>GDTB82Q225</b>
Ref. No.	—
Speed ratio	—
RPM Max.	—
Tool clamping	Ø25



**Sub Spindle Boring Bar Holder**

Product No.	<b>GDWB82Q306~320</b>
Ref. No.	—
Speed ratio	—
RPM Max.	—
Tool clamping	Ø6/8/10/12/16/20

### SW32



**Cross drilling/milling unit**

Product No.	<b>GDWA120301</b>
Ref. No.	LL-30U4A-A00
Speed ratio	1:1
RPM Max.	6000
Tool clamping	ER20



**3-spindle drilling/milling unit**

Product No.	<b>GDWA2A3301</b>
Ref. No.	—
Speed ratio	1:1
RPM Max.	8000
Tool clamping	ER20M



**Drilling/milling unit for sub spindle**

Product No.	<b>GDWB120301</b>
Ref. No.	LL-30U4A-A00
Speed ratio	1:1
RPM Max.	6000
Tool clamping	ER20M



**Drill holder for sub spindle**

Product No.	<b>GDWB81Q301</b>
Ref. No.	—
Speed ratio	—
RPM Max.	—
Tool clamping	ER20M

### SW32II



**Cross drilling/milling unit for sub spindle**

Product No.	<b>GDWB316301</b>
Ref. No.	—
Speed ratio	1:1
RPM Max.	6000
Tool clamping	ER16M

### SW20



**Drill holder for sub spindle**

Product No.	<b>GDWB81Q201</b>
Ref. No.	LC-3004
Speed ratio	—
RPM Max.	—
Tool clamping	ER16M

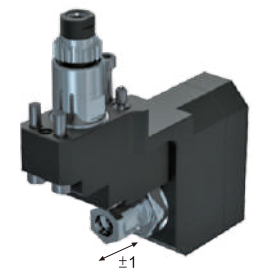

**Cross drilling/milling unit for sub spindle**

Product No.	<b>GDWB311201</b>
Ref. No.	—
Speed ratio	1:1
RPM Max.	4000
Tool clamping	ER11A